

# MAJORPOWER

## Majorsine Power Inverter

INSTALLATION & OPERATION MANUAL



Majorpower Corporation

7011 Industrial Drive

Mebane, NC 27302

Tel: 919.563.6610

## Revision History

Document #	Date	Release Type
M121.0	January 2024	Initial
M121.1	May 2024	MP + FOA

## Copyright Notice

©2024, Majorpower Corporation. All rights reserved. This document may not be copied in whole or in part, or transferred to any other media, without the written permission of Majorpower Corporation. Printed in the United States of America.

Majorpower® and MAJORSINE® are registered trademarks.

## Warranty

Majorpower Corporation Warranty Summary for MAJORSINE products.

A 24-month manufacturer warranty is in effect for the MAJORSINE Power Inverter product family.

The standard warranty includes factory repair or replacement of any unit that fails during the first 24 months due to a defect in materials or workmanship. Any unit returned to the factory under warranty request will be repaired or replaced at the discretion of Majorpower Corporation. A Warranty Claim unit should be returned freight prepaid against a Return Material Authorization (RMA) for evaluation.

Obtain an RMA Case number, by calling 888-708-6610 or email: [tech-support@majorpower.com](mailto:tech-support@majorpower.com) for assistance. The customer is responsible for prepaying freight of equipment to the service center. The repaired or replacement unit will be returned to the user, freight prepaid (limited to North America locations) by the factory, if the repair is covered under warranty.

Notes and Conditions:

- An authorization (RMA Case Number) is required to return any equipment.
- Out of Box replacements will be shipped for 2<sup>nd</sup> day delivery, within North America.
- An Out of Box Failure must occur and be reported within 30 days of the original shipping date.
- Additional test evaluation charges may apply to equipment tested and found to be in proper operation. Otherwise declared as No Fault Found: NFF.
- All advance replacements will be shipped against the customer's credit card or purchase order. If the defective unit is not received by Majorpower within 15 days, the invoice will be issued for immediate payment and due upon receipt.
- Majorpower reserves the right to supply repaired or equivalent units as replacements.
- Warranty timestamp is linked to the serial number on the original day a unit ships from the manufacturer's warehouse.

## Table of Contents

1.	INTRODUCTION	5
1.1.	General Information	5
1.2.	Manual & Model Applicability	5
2.	IMPORTANT SAFETY INSTRUCTIONS	6
2.1.	Safety Statement	6
2.2.	Additional Safety Notes	6
2.3.	Symbols	7
2.4.	Equipment Advisory	7
2.5.	Terms in Use	9
3.	PRODUCT OVERVIEW	10
3.1.	System Features	10
3.2.	Block Diagram & Priority Mode	10
3.3.	Front Panel	11
3.4.	Rear Panel	12
3.5.	Bypass Switching and Grounding	13
3.6.	DC System Ground Connection Types	14
4.	INSTALLATION	14
4.1.	Delivery of Equipment	14
4.2.	Installation Hardware Kit	14
4.3.	Installation Input Procedures	14
	Install Source DC Input Voltage:	15
	Install Source AC Input Voltage:	16
	Install Alarm System Wire:	16
4.4.	A: Connecting the Loads with Receptacles	18
4.5.	B: Connecting the Loads with Hardwire	19
5.	OPERATION	20
5.1.	Energize the Input Power	20
5.2.	Front Panel Operation – Settings @ Start-Up	21
5.3.	Main Menu Flow	21
5.4.	Screen and Button Navigation	23
6.	MAINTENANCE AND TROUBLESHOOTING	25
6.1.	Maintenance	25

6.2.	Troubleshooting	26
6.3.	Alarms, Relays and Thresholds	27
6.4.	Bypass Utility AC Operation Thresholds	28
6.5.	LED Indications	28
6.6.	Elevated Temperature	29
7.	Relay and Network Connection	29
7.1.	Dry Contact Communication Terminal	29
7.2.	Communication Expansion Card Slot (TCP-IP / WEB)	30
8.	TECHNICAL SPECIFICATIONS	31
8.1.	MAJORSINE 48 Vdc models	31
8.2.	MAJORSINE 130 Vdc Models	32
8.3.	Drawing No. D121.0-1U	34
9.	Frequently Asked Questions:	35
10.	Optional Hardware:	37
11.	Ordering Equipment:	38
12.	Remote Access Library:	39
13.	Technical Service Contact Information:	40
	Table Index	40

# 1. INTRODUCTION

## 1.1. General Information

Thank you for choosing MAJORPOWER Corporation as the power products supplier to your company. MAJORSINE Power Inverters are designed and built for full reliability at multiple locations and a variety of applications. These intelligent, dependable inverters provide economical AC power for all your network needs. Operators spanning global continents have deployed a MAJORSINE as the choice for high availability AC power support from a DC source.

This manual contains information and technical details for all models in the MAJORSINE Power Inverter family. The operation procedures are common, however in some instances, all or part of the information may not apply to the specific model purchased. Refer to the specific model details page in Chapter 8: Technical Specifications.

Should you require any assistance, please call our Application Engineering department at:



**Telephone: (888) 708-6610 or (919) 563-6610**

**Email: [tech-support@majorpower.com](mailto:tech-support@majorpower.com)**

## 1.2. Manual & Model Applicability

Model Numbers -
MAJORSINE 500-48-1U
MAJORSINE 1000-48-1U
MAJORSINE 2000-48-1U
MAJORSINE 500-130-1U
MAJORSINE 1000-130-1U
MAJORSINE 2000-130-1U

Product Family, Watts Capacity – Input Voltage – Chassis Size

## **2. IMPORTANT SAFETY INSTRUCTIONS**

### **2.1. Safety Statement**

SAVE THESE INSTRUCTIONS - This manual contains important inverter instructions that should be followed during installation and maintenance of the MAJORSINE inverter unit.

To reduce the risk of electric shock, install the inverter in a temperature and humidity controlled indoor environment, free of conductive contaminants. Ambient temperature should not exceed 70°C.

- Depending on use, the AC output of the inverter may require a customer installed disconnect or fusing. The inverter offers standard AC short circuit protection.
- The following precautions should be respected when working on the inverter:
- Remove watches, rings, or other metal objects.
- Use tools with insulated handles.
- Wear rubber gloves and boots.

### **2.2. Additional Safety Notes**

- Upon receipt, examine the shipment box for damage. Notify the carrier immediately before opening if damage is evident.
- Do not open or disassemble the inverter, warranty will be voided.
- Do not operate near water or in excessive humidity.
- Keep liquid and foreign objects from entering the inverter.
- Install the inverter in a well-ventilated area. Do not block front air vents, or rear air exhausts of the unit.
- Do not operate the inverter close to combustible gas or open fire.
- Do not plug appliances with surging loads, or half bridge rectified loads, into the inverter.
- Do not operate the inverter if the unit is leaking any liquid or if a white powdery residue is found to be present.
- Temperature: The inverter should be operated in an ambient temperature range of 0°C to +70°C or output efficiency may be affected. Air flow to the inverter must not be impeded.
- Reduced air flow: Installation of the equipment in a rack should be such that the amount of air flow required for safe operation of the equipment is not compromised.
- Mechanical loading: Mounting of the inverter in a rack should be level and balanced.
- Wiring: Adequate input power must be supplied to the inverter for proper use; correct wiring sizes must be respected.
- Grounding: Reliable grounding of rack-mounted equipment should be maintained.
- Inverter DC power connection must be from a dc source within the technical specifications of the unit under installation.

### 2.3. Symbols

PROTECTIVE GROUNDING TERMINAL: A terminal, which must be connected to earth ground prior to making any other connection to the equipment.

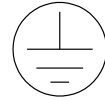

This symbol indicates the word "phase".

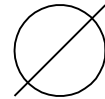

This user's manual contains important technical instructions to be followed by qualified personnel responsible for the installation, start-up and maintenance of this unit. It is recommended that this manual be read attentively to ensure safe and reliable operation of this equipment.

### 2.4. Equipment Advisory

**DANGER:**

Risk of electric shock, do not touch uninsulated battery terminal.

**HIGH LEAKAGE CURRENT:**

Earth connection is essential before connecting supply.

**WARNING:**

To reduce the risk of fire or electric shock install in a temperature and humidity controlled indoor area free of conductive contaminants. Refer servicing to qualified service personnel only. Intended for installation in a controlled environment.

**CAUTION:**

Risk of electric shock, capacitor stores hazardous energy. Do not remove cover until 5 minutes after disconnecting all sources of supply.

Risk of electric shock-hazardous live parts inside this unit are energized from the dc current supply even when the input ac power is disconnected.

Risk of electric shock, do not remove cover. No user serviceable parts inside. Refer servicing to qualified service personnel.

Risk of electric Shock! This inverter receives power from more than one source- disconnection of the ac sources and the dc sources is required to de-energize this unit before servicing.

Risk of electric shock-hazardous live parts inside this unit are energized from the dc or bypass ac input, isolating dc and ac input is essential before working on this unit.

**DANGER:**

Risque d'électrocution, ne touchez pas la borne non isolée de la batterie.

**COURANT DE FUITE ÉLEVÉ:**

Raccordement à la terre indispensable avant le raccordement au réseau.

**AVERTISSEMENT:**

Pour réduire le risque d'incendie ou d'électrocution, installez dans un espace intérieur à température et humidité contrôlées, exempt de contaminants conducteurs. Confiez l'entretien à du personnel de service qualifié uniquement. Destiné à être installé dans un environnement contrôlé.

**PRUDENCE:**

Risque d'électrocution, le condensateur stocke de l'énergie dangereuse. Ne retirez pas le couvercle avant 5 minutes après avoir débranché toutes les sources d'alimentation.

Risque d'électrocution : les pièces sous tension dangereuses à l'intérieur de cet appareil sont alimentées par l'alimentation en courant continu même lorsque l'alimentation CA d'entrée est déconnectée.

Risque d'électrocution, ne retirez pas le couvercle. Aucune pièce réparable par l'utilisateur à l'intérieur. Confiez l'entretien à un technicien qualifié.

Risque d'électrocution ! Cet onduleur est alimenté par plus d'une source - déconnexion des sources CA et les sources CC sont nécessaires pour mettre cette unité hors tension avant l'entretien.

Risque d'électrocution Les pièces sous tension dangereuses à l'intérieur de cet appareil sont alimentées par l'entrée CC ou dérivation CA, l'isolation des entrées CC et CA est essentielle avant de travailler sur cet appareil.

---

**PELIGRO:**

Riesgo de descarga eléctrica, no toque el terminal de la batería sin aislamiento.

**ALTA CORRIENTE DE FUGA:**

Es esencial la conexión a tierra antes de conectar el suministro.

**ADVERTENCIA:**

Para reducir el riesgo de incendio o descarga eléctrica, instálo en un área interior con temperatura y humedad controladas y libre de contaminantes conductores. Refiera el servicio solo a personal de servicio calificado. Diseñado para su instalación en un entorno controlado.

**CAUTELA:**

Riesgo de descarga eléctrica, el condensador almacena energía peligrosa. No retire la tapa hasta 5 minutos después de desconectar todas las fuentes de suministro.

Riesgo de descarga eléctrica: las partes vivas peligrosas dentro de esta unidad se energizan desde el suministro de corriente continua, incluso cuando se desconecta la alimentación de CA de entrada.

Riesgo de descarga eléctrica, no retire la cubierta. No hay piezas reparables por el usuario en el interior. Refiera el servicio a personal de servicio calificado.

¡Riesgo de descarga eléctrica! Este inversor recibe energía de más de una fuente: se requiere la desconexión de las fuentes de CA y las fuentes de CC para desenergizar esta unidad antes de servicio.

Riesgo de descarga eléctrica Las partes vivas peligrosas dentro de esta unidad se energizan desde la entrada de CC o CA de derivación, es esencial aislar la entrada de CC y CA antes de trabajar en esta unidad.

## 2.5. Terms in Use

### **DANGER:**

Indicates a hazardous situation that will result in death or serious injury, if not avoided.

### **WARNING:**

Indicates an injury or hazard potential may occur, if not avoided.

### **CAUTION:**

Indicates potential damage to equipment, property or could result in minor injury.

AC - Alternating-Current Voltage; inverter output or a connection to the bypass input.

Authority Having Jurisdiction (AHJ) - The organization, office, or individual responsible for approving equipment, materials, installation, or a procedure.

AWG - American Wire Gauge is a logarithmic stepped standardized wire gauge system used since 1857.

Bypass Circuit - The AC Voltage circuit connected to the secondary input of the inverter from the utility service or alternative ac source. (BYP)

DC - Direct-Current Voltage; a connection to the dc inverter input.

Electrical Hazard - A dangerous condition such that contact or equipment failure can result in electric shock, arc-flash burn, thermal burn, or blast.

Skilled Person - One who has skills and knowledge related to the operation of this electrical equipment and installations plus has received safety training on the hazards involved. The person should be able to apply their knowledge and skills as a safeguard against pain and injury.

### 3. PRODUCT OVERVIEW

#### 3.1. System Features

The MAJORSINE series inverter is a highly reliable DC-AC inverter system, designed with advanced power electronics and microprocessor technology offering the following features:

##### **Self-Diagnosis**

The MAJORSINE series inverter is equipped with a self-diagnosis microprocessor, able to identify and show all failure messages on the LCD display, with visual LED indicators.

##### **High Frequency Architecture**

With its high frequency architecture design, the MAJORSINE series inverter features high efficiency, light weight and compact design.

##### **Modular Design**

MAJORSINE inverters use a modular design structure, resulting in robust reliability and high MTBF rating. (mean-time-between-failures)

##### **High Efficiency**

MAJORSINE series inverters offer the advanced soft-switching design which increases operating efficiency and reduced switching noise.

##### **Advanced Protection Features:**

Input reverse polarity-proof protection

Input over/under voltage protection

Internal over temperature protection

Output overload protection

Output over/under voltage protection

Output short circuit protection

DC input short circuit protection

Fan failure detection and protection

#### 3.2. Block Diagram & Priority Mode

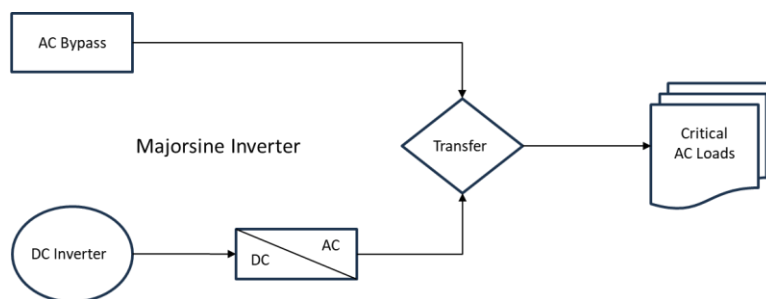

MAJORSINE inverters feature the latest macro SMT production, minimizing weight and dimension, while enhancing output short circuit reliability and overload capacity.

Inverter Output voltage is provided to loads in one of two modes:

- 1) **MODE DC: Inverter** / From DC input to AC Load.
- 2) **MODE AC: Bypass** / From AC input bypass to AC Load.

Either Priority Mode is front panel programmable; the selected operational mode will predetermine the “default” output. Factory production sets the priority to Mode DC: Inverter.

In the first option, **MODE DC: Inverter**, AC output power will be provided by the inverter from the dc source. Should the DC source or inverter circuit fail, the system will transfer output power through the bypass mode. Once the DC power source is restored, the system will revert to “inverter” mode.

In the second option, **MODE AC: Bypass**, AC output power will be supplied through the AC bypass circuit. Upon AC source fault, output power will be originated through the DC to AC inverter mode. Once AC source is restored, the unit will revert from inverter mode to bypass mode.

Transfer time from inverter to bypass, or bypass to inverter is rated to < 4 mSec.

The Priority Mode is configured by pressing the front panel controls when both input sources are available. The mode should not be changed during an abnormal or fault condition of either source.

### 3.3. Front Panel

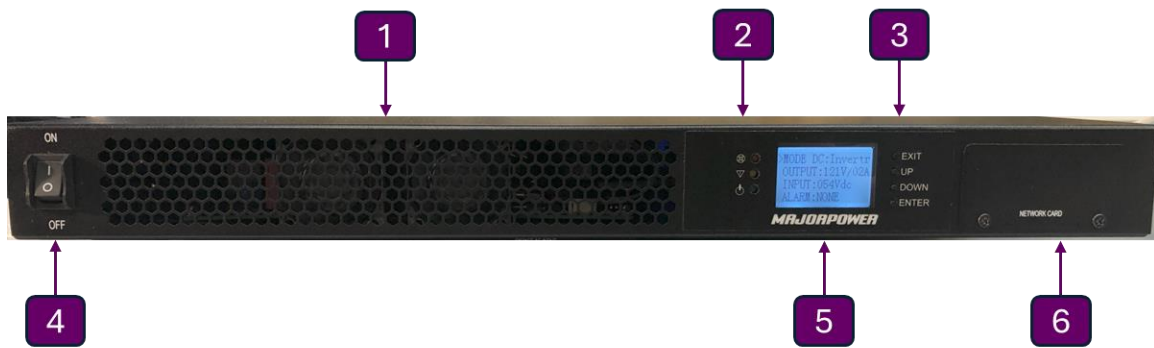

1	Ventilation	4	Output Control Switch
2	LED Status	5	LCD Menu
3	Menu Navigation	6	Network Card Access

### NAVIGATION BUTTONS:

These are user input controls for navigating the menu structure and making parameter changes.

The buttons include: Exit, Up, Down and Enter.

### LEDs:

Indications of the operation status at a glance. Red is a Major class alarm, Yellow is a Minor class alarm and Green is for source condition. The Green source LED will present three conditions including dark for OFF, solid illumination to one source and blinking illumination for two sources energized.

### STATUS CLASS:

Indicates that the inverter is reporting a “triggered” condition. Classifications include Major and Minor which are mapped to the LEDs and Dry-Contact relays.

### DISPLAY SELECTION MENU

Data display for output voltage, load (W & A), input dc voltage, bypass ac voltage, bypass Hz and system status can be shown on the LCD display by pressing these navigation buttons.

### VENTED FRONT

The front panel ventilation allows fresh air flow for inverter component cooling. Do NOT obstruct this inlet or the fan exhaust port in the back of the unit! Clean on a regular interval.

### OUTPUT CONTROL SWITCH

The toggle switch will activate the inverter control circuits to pass AC voltage to the output connection, therefore powering the attached load equipment. Reverse polarity protection (input) is integrated within the internal circuitry and will prevent inverter operation without damage. The switch is located on the front left sector of the inverter. This switch is also used to initiate restart after a capacity overload event and excessive current-draw loads are removed from the circuit.

## 3.4. Rear Panel

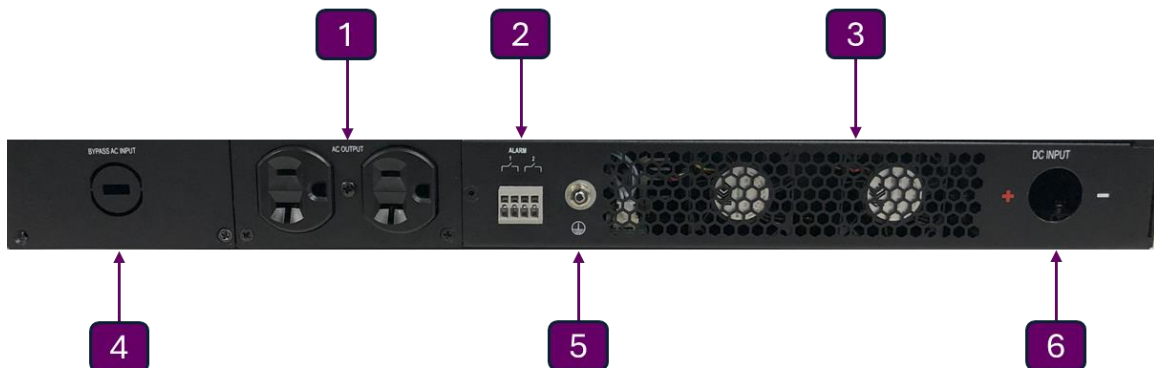

1	AC Output	4	AC Input
2	Alarm Relays	5	Ground Stud
3	Ventilation	6	DC Input

### AC OUTPUT (RECEPTACLE / HARDWIRE)

Receptacle = NEMA 5-15R or NEMA 5-20R (per capacity of unit)

Hardwire = 3-Wire Integrated Barrier Terminal Option

### AC INPUT TERMINAL

Integrated power distribution block for bypass AC input voltage.

### COMMUNICATION INTERFACES

MAJORSINE Inverters provide two standard and integrated communication interfaces.

- a) Dry-Contact Alarm Relays interface block. (back panel)
- b) The network communication card is an available option; Section 10. (front panel)

### DC INPUT TERMINAL

Integrated power distribution block for DC input voltage.

Floating input "+" and "-" connection.

### DRY CONTACT TERMINAL – Alarms

Dry contact terminal for 2 relays. One for each class of alarms sorted by Major (Red) + Minor (Yellow). The relay contact terminal can switch up to 5A / 250 Vac from the user's telemetry system circuits.

### FANS

Inverter ventilation is provided by integrated fans, programmed and thermally responsive to changing load conditions. Forced air flow is from front-to-back. A short fan test is performed during the self-check starting procedure.

## 3.5. Bypass Switching and Grounding

### Operation = Mode DC: Inverter

DC input supplied from battery/DC power system,

Inverter originated AC, therefore neutral to earth connection is provided internally.

### Operation = Mode AC: Bypass

AC input supplied from local utility service panel,

AC pass-through neutral to earth connection provided externally.

**DANGER - Inverter Safety Grounding:** The Chassis-to-Earth Ground connection shall be made per the user's installation specifications or prevailing safety jurisdiction authority. The grounding is mandatory for skilled personnel safety.

*The inverter external chassis ground bond is not switched in any operational mode. Typically, the chassis is mounted in a rack and a safety conductor to earthed ground is installed. Often a centralized connection point is made to the master ground bar in the location.*

### 3.6. DC System Ground Connection Types

The floating DC input allows many system applications to use the Majorsine inverter. It is crucial to note that the positive and negative input voltage terminals of all Majorsine inverters float relative to chassis and earth.

The installation and application parameters dictate if or how a system is referenced to earth for grounding. Two typical system types are illustrated below.

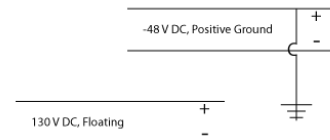

The inverter DC input is floating, therefore suitable applications -48 V telecom applications and floating 130 V utility installations.

## 4. INSTALLATION

### 4.1. Delivery of Equipment

Check the condition of the package upon receipt of the equipment. Refuse receipt and/or contact your shipper immediately to initiate your freight claim, if the package or internal contents are damaged.

### 4.2. Installation Hardware Kit

Contents of the kit include:

- Majorsine Installation – Setup Guide
- Poly zip bag containing M4 screws
- Two mounting brackets (19" rack application)
- Rack threads vary widely; User Provided Item

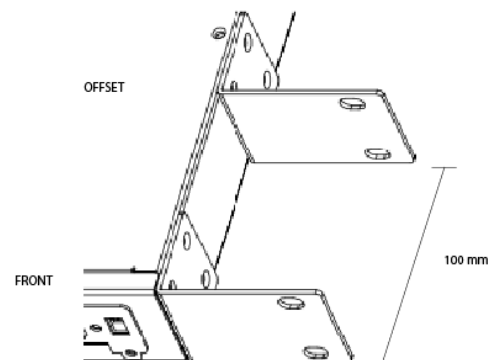

### 4.3. Installation Input Procedures

Mount the unit in a rack using the brackets and screws supplied in the hardware kit. (small box within main carton) Begin by fitting the ears to the side of the inverter. Two positions are available; Front-Flush and 3.94 inch (100mm) Offset.

Secure the inverter in the designated rack. Ensure it is properly fixed to avoid any movement or instability. Before proceeding, disconnect and lock-out all AC sources and DC battery voltages.

### **Install Source DC Input Voltage:**

Please check that the input DC voltage supply meets the dc specification of the inverter and verify the correct DC polarity connections will be made to the inverter. It is crucial to ensure that the power source is turned off during this step to prevent sparks, which can occur due to the internal capacitance of the inverter.

***WARNING:*** DC source voltage must be within the normal operating range for the equipment. (REF – DC Voltage Thresholds / Table 4)

Turn off and lock-out the DC source circuit protection device (breaker; fuse) before connecting the DC voltage wires to the input terminal. The DC terminal block will accommodate wire sizes recommended in the chart below. (8-12 AWG) The chassis wire entry port is 0.39x0.78 inch (10x20mm). Connect the DC input wires to the inverter.

***CAUTION:*** Sparks may occur if the source is “ON” when connecting the input DC voltage wire. Inrush is a normal condition due to the charge-current from the DC voltage source energizing the internal capacitance of the inverter.



Strip the wire insulation 1/3 inch (9-11 mm). Insert the DC input wires into the '+' and '-' terminal block and secure with the screw using 10.6-13.0 lbf-in. Install the chassis protection cover and secure wires with the strain relief.

### Install Source AC Input Voltage:

Lockout the AC source breaker. Remove the hardwire access safety cover. Route the cable and strain relief into the safety cover. Connect the AC bypass service supply wires. Single phase 120 Vac/60 Hz nominal source. (Line-Ground-Neutral) Install the protection safety cover and secure wires with the strain relief.

**MAJ-LC515-06** is a pre-engineered cable to connect the bypass circuit input.  
(Optional Hardware; page 37)

Note that operating the inverter on bypass mode is possible until a DC circuit is provided.

An additional chassis earthing stud will mount conductors as needed for the installation site.

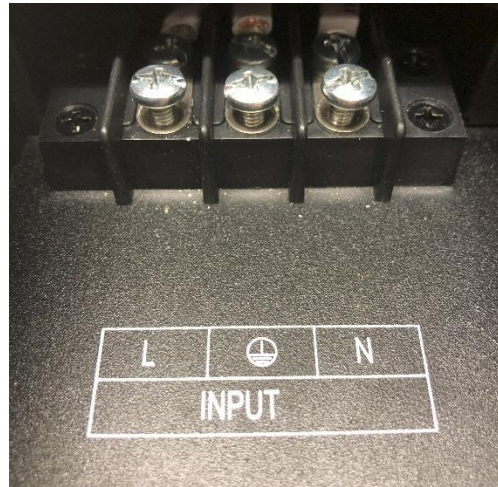

### Install Alarm System Wire:

Attach 22 AWG wire from the user provided alarm collection system to the relay block.

(REF: Relay and Network Connection

Dry Contact Communication Terminal)



Reference local standards or the AHJ for your installation requirements. Use the following recommended wire sizes when connecting source power to the inverter.

**Connection Guide / Table 1**

Inverter Model Capacity	DC Input			AC Input		AC Output
	Breaker <sup>1</sup>	Amps Max	AWG <sup>2</sup>	Amps Max	AWG	Duplex Receptacle
MAJORSINE500-48-1U 500 W	15	14	14	6.7	14	NEMA 5-15R 4.2 A max
MAJORSINE1000-48-1U 1000 W	30	28	10	13.3	14	NEMA 5-15R 8.3 A max
MAJORSINE2000-48-1U 2000 W	60	55.5	8	26.6	12	NEMA 5-20R 16.6 A max
MAJORSINE500-130-1U 500 W	10	5.5	14	6.7	14	NEMA 5-15R 4.2 A max
MAJORSINE1000-130-1U 1000 W	15	11	12	13.3	14	NEMA 5-15R 8.3 A max
MAJORSINE2000-130-1U 2000 W	25	22	12	26.6	12	NEMA 5-20R 16.6 A max

<sup>1</sup> Recommended ampere rating circuit breaker or refer to the local installation standard.

<sup>2</sup> Application recommended wire gauge. Cage Clamp maximum wire size is 8 AWG.

**WARNING:** Do not operate inverter with any access panel removed.  
All protective covers shall be in place before energizing the inverter.

#### 4.4. A: Connecting the Loads with Receptacles

Calculate the total power consumption (W=watts) of the load being attached to the output. Ensure the total power consumption does not exceed the inverter output rating.

Utilize the NEMA receptacle when adding load equipment to the inverter output circuit.

The measured load consumption can be monitored on the front screen of the inverter using the navigation buttons and reviewing the Output Menu.



Energize input circuits and toggle the ON switch to activate the operation circuit for energizing the output connection. Verify the load equipment is operational.

OVERLOAD alarm is created when the total load exceeds the capacity of the inverter. Remove loads until the total current requirement is within the rated capacity of the inverter. Distribute removed loads to alternate sources or additional inverters.

**WARNING:** Do not operate inverter with any access panel removed.

All protective covers shall be in place before energizing the inverter.

#### 4.5. B: Connecting the Loads with Hardwire

Calculate the total power consumption of the load being attached to the output. Make sure that the total power consumption does not exceed the rated load of the inverter.

Utilize the accepted wire capacity guide when adding load equipment to the inverter output circuit. (REF: Connection Guide / Table 1)

Remove the NEMA access panel screws from the chassis.

Pull the NEMA assembly back to expose the terminal block and release the three-wire connection attaching the NEMA interconnect to the inverter power-barrier block.



Attach the desired load circuit to the inverter terminal block (OUTPUT), route the wire bundle through the safety cover, strain relief and mount the access cover to the chassis. An additional safety cover, with  $\frac{3}{4}$  inch knock-out, is included with the inverter.

Energize input circuits and toggle the ON switch to activate the operation circuit for energizing the output connection. Verify the load equipment is operational.

**WARNING:** Do not operate inverter with any access panel removed.

All protective covers shall be in place before energizing the inverter.

## 5. OPERATION

Pre-check the operation before connecting a load apparatus.

### 5.1. Energize the Input Power

Verify the DC source power wire is properly connected, engage the DC source circuit protection device (breaker; fuse) to activate the inverter front panel for parameter configuration.

Verify the AC source power wire is connected, engage the AC source circuit breaker. This circuit breaker may be in a utility service panel.

After an initial "**Majorsine BOOTING**" routine, verify the operation Priority Source selection menu and make setting changes as needed for the application.



Check the Operation Settings:

Refer to the screen flow "MODE" to change the default setup of the inverter. Select ">MODE"; press "ENTER".

Adjust the inverter settings for operation to match the application.

## 5.2. Front Panel Operation – Settings @ Start-Up



The inverter will automatically initiate self-checks and display “Majorsine Booting”. If no configuration changes are made using the front panel buttons, the factory presets will be deployed for basic operation.

Priority = Mode DC:Inverter

Output = 120 V / 60 Hz

Using Bypass = Yes

## 5.3. Main Menu Flow

Review the inverter operation using the Main Menu displayed on the LCD screen.



Parameters include:

### A) Mode:

Shows present operation mode and priority source.

This will be either Mode DC:Inverter or Mode AC:Bypass.

Selections: output voltage and bypass utilization

### B) Output:

Shows present output voltage and current draw.

Read Data

### C) Input:

Shows present input source data; either DC or AC based on the mode.

Read Data

### D) Alarm:

Shows present alarm and at boot displays “none”.

Selections: Relay Class, Date & Time, Event Log

Read: Active Alarms and Alarm Log

# Additional Menu Selections

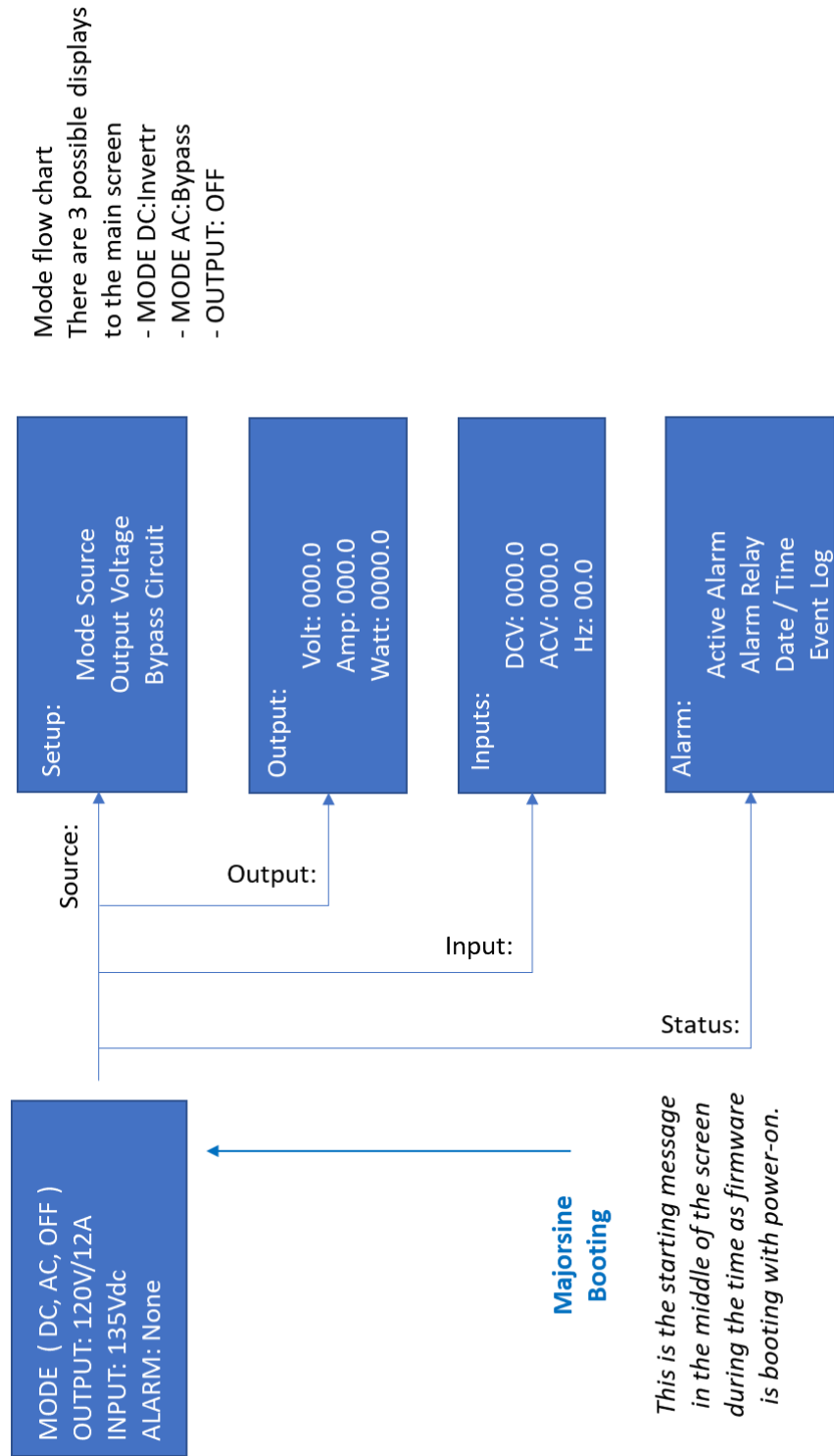

Mode flow chart

There are 3 possible displays to the main screen

- MODE DC: Invert
- MODE AC: Bypass
- OUTPUT: OFF

## 5.4. Screen and Button Navigation

Review these common inverter operations using the step-by-step procedures.

The Menu Tree is programmed with a 2-minute reset timer based on no-activity. The Main Screen is presented at the end of the time out period.

### Mode Source

1. Main Screen > "Mode" press ENTER
2. Press DOWN to > "Mode Source"
3. Press ENTER to see the options.

Screen Display: Mode DC: Inverter  
Mode AC: Bypass

4. Default setting is Mode DC: Inverter. Press DOWN/UP to move the cursor (>).
5. Press ENTER to save the selection.

### Output Voltage

1. Main Screen > "Mode" press ENTER
2. Press DOWN to > "Output Voltage"
3. Press ENTER to see the options.

Screen Display: 120 V  
115 V  
110 V

4. Default setting is 120 V. Press DOWN/UP to move the cursor (>).
5. Press ENTER to save the selection.

### Bypass Circuit

1. Main Screen > "Mode" press ENTER
2. Press DOWN to > "Bypass Circuit"

3. Press ENTER to see the options.

Screen Display: Use AC bypass:  
YES  
NO

4. Default setting is NO. Press DOWN/UP to move the cursor (>).
5. Press ENTER to save the selection.

### Alarm Relay

1. Main Screen > "Alarm" press ENTER
2. Press DOWN to > "Alarm Relay"
3. Press ENTER to see the Dry Contact Operation options.

Screen Display: Normal-Close  
Normal-Open

4. Default setting is Normal-Close. Press DOWN/UP to move the cursor (>).
5. Press ENTER to save the selection.

### Date/Time

1. Main Screen > "Alarm" press ENTER
2. Press DOWN to > "Date/Time"
3. Press ENTER to see the Dry Contact Operation options.

Screen Display: 14:40:00  
07/04/2024

4. Press DOWN/UP to move the cursor (>).
5. Press ENTER to selection and change a parameter. Example; one press will cause the first position 0 in 07/04/2024 to oscillate.
6. While oscillating, press DOWN/UP to update a value.
7. Press ENTER to save the selection and activate the next position for update.
8. When all fields are accurate, the cursor (>) will flash.
9. Press EXIT and return to the main screen.

#### Event Log

1. Main Screen > "Alarm" press ENTER
2. Press DOWN to > "Event Log"
3. Press ENTER to see the most recent alarm numbered 1.
4. Screen Display: (press DOWN or UP to review the two pages)
  - 4.1. Page A: Event Log Number, Time, Date
  - 4.2. Page B: The Event Name
5. Press ENTER to review the next log entry.

The Event Log is a ten-entry file design. The log entry starts at 1 and fills the next open position with a new alarm. As a Round-File, the number 1 position will be overwritten after position 10 is filled, then the new entries will process through the log again. Pressing enter navigates from 1 to 10. Pressing Exit returns the first level "Event Log" selection to start the review process at #1.

Entries will be saved even with a two-input source outage. *(sample screen below)*  
As an example, the inverter controller maintains capacitance to operate for approximately 7.5 seconds and write an outage event to the log.



## **6. MAINTENANCE AND TROUBLESHOOTING**

### **6.1. Maintenance**

Make sure that the inverter vents are not blocked.

Use a vacuum cleaner to clear any dust from the fan area.

When cleaning the case or front panel, use a soft, dry cloth, only. If the case or front panel is very dirty, use a neutral, non-abrasive detergent. Do **not** use alcohol or ammonia-based solutions.

Regular service, and movement of the inverter, should be performed by a qualified service technician.

Avoid spilling liquid on the inverter.

**DANGER:** Do not open inverter main chassis top cover. NO user serviceable parts inside.  
Refer servicing to qualified service personnel. Risk of electric Shock!  
All access safety covers shall be in place before energizing the inverter.

## 6.2. Troubleshooting

**Resolution Guide / Table 2**

Problem	Possible cause	Action to take
LEDs do not light up	Source Input circuit protection device is "OFF"	Turn on or reset the protection device.
	DC wire polarity installation is wrong	Meter check & Apply correct DC polarity.
	DC input voltage is "over" or "under" rating	Apply correct DC voltage.
No Output Voltage	Control Switch Position	Toggle the front panel switch from OFF to ON.
	Input Source	Verify the presence of DC or AC input source circuits
Loads Not Powering ON	Connection or Wiring to the output of the inverter	Inspect the load line cord connection to the NEMA receptacle or wire connections if using the hardwire option.
"OVERLOAD" Alarm	The AC power drawn from the inverter exceeded the load rating of the inverter.	Reduce the load to below 100% of the inverter rated capacity. Remove loads or redistribute loads to other inverters. FULL power OFF reset without loads connected. Incrementally add each load and monitor the OUTPUT Menu.
LCD H-TEMP Alarm	Temperature inside the inverter is too high.	Check for blocked vents or non-working fan. Evaluate the site environmental status.
Fan Fail Alarm	Fan internal speed indication	If the fan is blocked, remove the cause. If the fan fails to operate, return the inverter for service.
No transfer from the DC source to the AC source.	Out-of-Range ac source	Measure the source & correct.
	Bypass Configuration mismatch	Configure Bypass equal to YES (see section 5.4)

Software commissioning allows the user to enable/disable bypass circuit condition notifications. The inverter can operate without the AC bypass connection notifications in the DC Input Only configuration.

### 6.3. Alarms, Relays and Thresholds

**Inverter Alarm Classifications & Relay Map / Table 3**

Screen Display	Alarm Name	Action/Sensor	Mapped Relay / LED
DC Fault	DC Fault	DC Voltage Off (0.0)	Major Alarm / RED
Overload	Inverter Overload	Current Measurement	
Short	Output Short Circuit	Self-Protection Mode	
Inv Fail	Inverter Internal Fault	Non-Operational Condition	
Temp: OFF	H Temp Shutdown	Shutdown without BYP avail for transfer	
Byp Volt	Bypass AC Voltage Fault	AC Voltage High or Low	Minor Alarm / YELLOW
Byp Hz	Bypass AC Frequency Fault	Frequency out of Tolerance	
H Temp	High Temperature Warning	Temperature = 60°C	
DC Fault	DC Fault	DC Voltage High or Low	
Fan Fail	Fan Fault	Low or No Rotation	

**DC Voltage Thresholds / Table 4**

DC Voltage Input	48 V	130 V	Indication
DC Low Voltage Fault	40	100	Red LED
DC Low Voltage Warning	42	105	Yellow LED
<b>Normal Operation Range</b>	<b>42 - 58</b>	<b>105 - 145</b>	<b>Green LED</b>
DC High Voltage Warning	58	145	Yellow LED
DC High Voltage Fault	60	150	Red LED

Overload Indicator:

The AC power (watts) drawn from the inverter exceeded the load rating of the inverter. To clear this condition status; ① the load must be reduced to within published specifications of the connected inverter, ② the input source(s) must be available and stable.

Current draw >100% capacity will initiate a RED pulsing LED and start the internal timer.

**Output Capacity Rating / Table 5**

0 ~ 104% rating	continuous operation
105% ~ 125% rating	for 3 minutes
126% ~ 150% rating	for 3 seconds
> 150% rating	for 1 second
- shutdown OUTPUT without damage	"Latch-Off" + Solid Red LED



The Red solid lit LED indicates the overload condition has exceeded the timer, per the capacity rating table. Latch-Off recovery process includes actuating the switch OFF then ON to start inverter operation with a reduced load connected.

**6.4. Bypass Utility AC Operation Thresholds**

**Single Phase AC Voltage Bypass / Table 6**

User Selectable Output Voltage	O/P = 110; 115, 120 Vac / 60 Hz / 1 Ø
AC Bypass Voltage Range	110-130 Vac ±10 % (100-140)
AC Bypass Frequency Range	60 Hz ±10%
AC Bypass Recovery From Over Voltage	135 Vac
AC Bypass Recovery From Under Voltage	105 Vac

**6.5. LED Indications**

Inverter Normal Operation Range of Input Source

Green LED Status

- 0 Source within range = OFF
- 1 Source within range = Solid ON
- 2 Sources within range = Blinking or Oscillation off/on

Yellow LED Status / Minor alarm:

a condition is out-of-tolerance and alerts the user that attention is required, or it could result in a future outage fault.

Red LED Status / Major alarm:

- blinking condition out-of-tolerance with timer started on pending fault.
- solid condition the fault parameter needs immediate attention and service effecting.

## 6.6. Elevated Temperature

Inverter normal temperature operation range is -20 to 50°C. The inverter over-temperature warning alarm (H Temp) will be activated at 51°C. (Minor Alarm Relay – Yellow LED)

Inverter output capacity shall derate:

~ between 51-60 °C, the load decreases linearly from 100% to 75%.

~ between 61-65 °C, the load decreases linearly from 75% to 50%.

~ between 66-70 °C, the load remains at 50%.

When the temperature exceeds 70 °C, it will transfer:  
to Mode AC:Bypass or shutdown without AC:Bypass circuit availability.

Operation recovery initiates @ 65°C which is 50% derating capacity of operation.

## 7. Relay and Network Connection

### 7.1. Dry Contact Communication Terminal

The “Dry-Contact” relay terminal is the interface for two relays on the rear of the inverter. The relays are used for switching the voltage provided by the user’s external alarm system.

The relays are designed for operation when the inverter is energized and operational with one of the two input power sources. The relays are fail-safe architecture; therefore, the NC (closed) condition is the default programmed operation with a resting state of the relay NO (open) when the inverter is powered off.

One contact set is for “Major” and the other one is for “Minor” class sorted alarms. The relay changes state when alarm parameters are analyzed then set by the controller. Alarms are triggered based on pre-programmed thresholds in the software.

Connection to the terminal should be made to external sensor circuits with appropriately sized wire. The contact terminals can support 5A/30 Vdc or 5A/250 Vac in either NC or NO configurations. NC/NO configurations are programmed with software using the navigation buttons. Factory preset is normal-close.

The terminal block is labeled 1 and 2 respectively Major and Minor alarm mapping. There are two spring-clamp terminals per relay.

Use a small gauge flat-blade screwdriver in the top portal to leverage the spring open, once open insert the stripped alarm wire in the lower access port on the spring-clamp block.



## 7.2. Communication Expansion Card Slot (TCP-IP / WEB)

Remote monitoring is a prime consideration and requirement to manage multiple network elements from a central location. Access is easy. Install the plug-n-play card, configuring the apparatus network IP address and attaching the network interface cable.

The NMC3 Card Kit includes:

➤ interface electronics card	➤ utilities CDROM and MIB file
➤ security cover plate	➤ quick installation guide

*(kit sold separately)*

The integrated expansion card slot is located on the inverter, behind a protective blank cover plate. Installation of the network management communication (NMC3) card and security plate is achieved using a standard #2 cross point screwdriver. Custom card IP network address programming is required using a PC interface. DHCP is enabled by factory default for network assigned IP numbering. Instructions for installation are included in the kit. Review Section 10 for Optional Hardware.

## 8. TECHNICAL SPECIFICATIONS

### 8.1. MAJORSINE 48 Vdc models

#### Specification 48 V / Table 7

DC Input	
Voltage	40-60 dc
Rated Current for Supply	14 Amps (500 W) 28 Amps (1000 W) 55.5 Amps (2000 W)
Protection	Fuse and Source DC Breaker
Efficiency- 48 Vdc I/P, 120 Vac O/P	>94% (full linear load)
AC Output	
Capacity	500 W 1000 W 2000 W
Voltage	110, 115, 120 ac / 1Ø
Voltage Regulation	±2%
Frequency	60Hz ± 0.2Hz
Wave Form	Pure Sine
THD (linear load)	3% 120 V/100%
THD (SPS load)	5% 120 V/100%
Crest Factor	3:1
Receptacles	NEMA 5-15R outlet (500; 1000) NEMA 5-20R outlet (2000)
Terminal (hardwire option)	3-Wire Integrated Barrier Block
Utility Power (Bypass)	
Voltage (120 Vac Nominal)	110-130 Vac ±10% (100-140)
Frequency	60± 5 Hz
External Protection	Source AC Breaker
Electronic Protection	
Short	For 1 second; Switch to Bypass, then shutdown
Overload	105-125% for 3 minutes; 126-150% for 3 seconds; >150% for 1 second; Switch to bypass
Temperature	-20 to 70°C; >51°C derating slope
Certifications	
Safety, ETL Listed	Conforms to Std. UL 62368-1 Cert. to CSA Std. C22.2#62368-1
EMC (EMI / RFI)	FCC Part 15; Class A / C63.4-2014 IEC61000-6-4
Immunity (surge / EFT)	IEC61000-6-2
Mechanical Dimensions	17.32"W x 13.8"D x 1.75"H 440 x 350 x 44.5mm 1U Rackmount
Weight	14.33 lbs / 6.50 kg

## 8.2. MAJORSINE 130 Vdc Models

### Specification 130 V / Table 8

DC Input	
Voltage	100-150 DC
Rated Current for Supply	5.5 Amps (500 W) 11 Amps (1000 W) 22 Amps (2000 W)
Protection	Fuse and Source DC Breaker
Efficiency- 130 Vdc I/P, 120 Vac O/P	>94% (full linear load)
AC Output	
Capacity	500 W 1000 W 2000 W
Voltage	110, 115, 120 AC / 1Ø
Voltage Regulation	±2%
Frequency	60Hz ± 0.2Hz
Wave Form	Pure Sine
THD (linear load)	3% 120 V/100%
THD (SPS load)	5% 120 V/100%
Crest Factor	3:1
Receptacles	NEMA 5-15R outlet (500; 1000) NEMA 5-20R outlet (2000)
Terminal (hardwire option)	3-Wire Integrated Barrier Block
Utility Power (Bypass)	
Voltage (120 Vac Nominal)	110-130 Vac ±10% (100-140)
Frequency	60± 5 Hz
External Protection	Source AC Breaker
Electronic Protection	
Short	For 1 second; Switch to Bypass, then shutdown
Overload	105-125% for 3 minutes; 126-150% for 3 seconds; >150% for 1 second; Switch to bypass
Temperature	-20 to 70°C; >51°C derating slope
Certifications	
Safety, ETL Listed	Conforms to Std. UL 62368-1 Cert. to CSA Std. C22.2#62368-1
EMC (EMI / RFI)	FCC Part 15; Class A / C63.4-2014 IEC61000-6-4
Immunity (surge / EFT)	IEC61000-6-2
Mechanical Dimensions	17.32"W x 13.8"D x 1.75"H 440 x 350 x 44.5mm 1U Rackmount
Weight	14.33 lbs / 6.50 kg

## Majorsine Inverter Product Family

**Statement of Technical Standards / Table 9**

Standard	Description
IEC 62368-1 ETL Listed	Product Safety Standard That Classifies Energy Sources Conforms to Std. 62368-1 Cert. to CAN/CSA Std. C22.2#62368-1
RFI-Emission	FCC Part 15; Class A / ANSI C63.4-2014
IEC 61000-6-4	Radiated Field Susceptibility; Emission
IEC 61000-6-2	ESD; Electrostatic Discharge Immunity
Altitude	-500 ~ 10,000 feet (storage 20,000')

### PART 15 INFORMATION TO THE USER <sup>1</sup>

1. For devices approved under Part 15, the user's manual or instruction manual for an intentional or unintentional radiator shall caution the user about changes or modifications to the device (Section 15.21).

2. For Class A and Class B digital devices, information to the user is required to include the following statements (Section 15.105):

- For a Class A digital device or peripheral, the instructions furnished to the user shall include the following or similar statement, placed in a prominent location in the text of the manual:

*NOTE: This equipment has been tested and found to comply with the limits for a Class A digital device, pursuant to part 15 of the FCC Rules. These limits are designed to provide reasonable protection against harmful interference when the equipment is operated in a commercial environment. This equipment generates, uses, and can radiate radio frequency energy and, if not installed and used in accordance with the instruction manual, may cause harmful interference to radio communications. Operation of this equipment in a residential area is likely to cause harmful interference in which case the user will be required to correct the interference at his own expense.*

**NOTE:** Changes or modifications to this product not authorized by Majorpower could void the electromagnetic compatibility (EMC) compliance and negate authority granted to the user by the FCC to operate this equipment.

---

<sup>1</sup> 784748 D01 General labeling and Notification v09r02

8.3. Drawing No. D121.0-1U

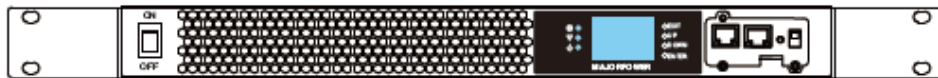
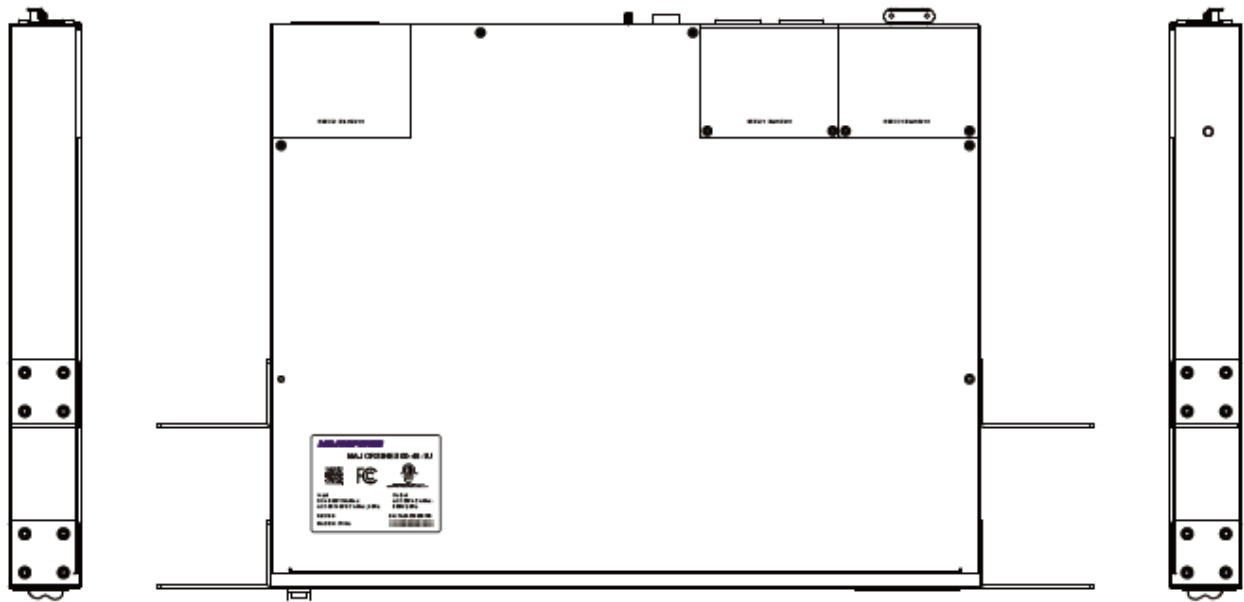
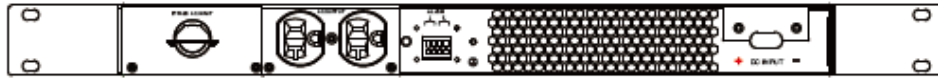

## 9. Frequently Asked Questions:

Question      What is the idle current draw (DC input) of the unit with no load on the ac output?

Solution  
Details

- 0.4 Amps for Majorsine500-48-1U & 500-48-1U
- 0.4 Amps for Majorsine1000-48-1U & 2000-48-1U
- 0.28 Amps for Majorsine1000-130-1U & 2000-130-1U

---

Question      Inverter; DC Input Supply Breaker Size?

Solution  
Details

48 V-500 W = 15 A  
48 V-2000 W = 30 A  
48 V-2000 W = 60 A  
130 V-500 W = 10 A  
130 V-1000 W = 15 A  
130 V-2000 W = 25 A

---

Question      Is this product positive ground, negative ground, or floating ground?

Solution  
Details

The dc input is designed as floating.  
The positive and negative input posts float relative to earth. The installation dictates if or how a system is referenced to earth.

**KEY:** The floating reference is only related to DC elements of equipment and is not related to any AC elements of equipment.

---

Question      What is the BTU output of the inverter operating fully loaded?  
(worst-case condition)

Solution  
Details

Watts 500 @ Efficiency 94%  
Difference (loss) 30  
BTU 102

Watts 1000 @ Efficiency 94%  
Difference (loss) 60  
BTU 204

Watts 2000 @ Efficiency 94%  
Difference (loss) 120  
BTU 409

Question Can I connect the AC output receptacle to the Bypass circuit input terminal on the same inverter?

Solution Details **NO:** The inverter is attempting to synchronize the internal AC phase clock and frequency output to the perceived external source. Since it is really being provided the internal clock source, the connection is creating a circular reference which is displayed by operational flicker. This is not an acceptable condition and may create unstable operation. The best solution is to connect the properly rated house supply circuit.

---

Question Does the inverter specification exceed input to output isolation >1500 Vdc?

Solution Details • **YES**

---

Question Can we connect the output of two inverters together for a capacity increase?

Solution Details • **NO; NON-WARRANTY DAMAGE** will be sustained in both units if the outputs are connected via any method. The load should be divided and spread across multiple units.

**10. Optional Hardware:**



NMC3; Network Management Communication:

Remote monitoring is a prime consideration and requirement to manage multiple network elements from a central location. Access is established by installing the plug-n-play card, configuring the apparatus IP-address and attaching the network interface cable.



---

Mounting Ear; 1U Bucket for 23-inch Rack Application:

Rack environments are not all the same. This engineered bracket is designed as a replacement mounting ear. Remove the kit supplied 19-inch ear, saving the chassis screws. Place the 23-inch ear on the chassis using the same screws. Mount in the 23-inch rack as required.

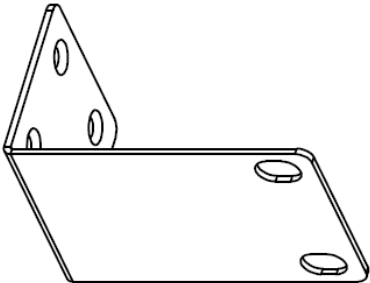

Cable Kit for AC Bypass; Pre-Engineered NEMA to Pigtail Spade:

Deploy the inverter with a pre-engineered cable to connect the bypass circuit input. This 6-foot (2M) engineered cable solution is designed using a molded NEMA 5-15P to pigtail (ROJ) with flange-spade lug for each wire. Strain relief for power cord assembly factory attached with each inverter system.

Connector Amp/Voltage: 15 A/125 V; SJT 14 AWG; 3 conductors



## 11. Ordering Equipment:

### Part Numbers / Table 10

Part Number	Group	Extended Description
Majorsine500-48-1U	Telecom Inverter	Input 40-59 Vdc, Output 120 Vac, 500 W
Majorsine1000-48-1U		Input 40-59 Vdc, Output 120 Vac, 1000 W
Majorsine2000-48-1U		Input 40-59 Vdc, Output 120 Vac, 2000 W
Majorsine500-130-1U	Utility Inverter	Input 100-150 Vdc, Output 120 Vac, 500 W
Majorsine1000-130-1U		Input 100-150 Vdc, Output 120 Vac, 1000 W
Majorsine2000-130-1U		Input 100-150 Vdc, Output 120 Vac, 2000 W
Majorsine-NMC3	Accessory	Network and Communication Card
MAJ-LC515-06		AC Bypass circuit; Line cord kit; 6'
MAJ-23B-1U		23" Rack Bracket, 1U, 2 pcs set

## 12. Remote Access Library:

RTA: Request for Technical Assistance

Additional Man-2-Machine interface documentation is available using the QR-Code and validating the power system being installed. Firmware is ever evolving with features therefore these documents are distributed electronically vs. print media.

Documents include firmware feature method of operation, MIB files and configuration parameter considerations.

Complete the form via the QR-Code when requesting download access.



( [www.majorpower.com/RTA-Form](http://www.majorpower.com/RTA-Form) )

Data Collection Note:

Majorpower Corporation takes the network security precautions of our customers seriously and, due to the nature of our products being deployed in critical application sites; we must verify the equipment ownership prior to releasing any documents that contain network and/or password access information. We appreciate your patience assisting us with compliance in our data collection and verification process before granting the requests for documentation.

**13. Technical Service Contact Information:**

If you have any questions or need more information regarding the correct operation of any Majorpower product, please use the following contact methods:

Majorpower Corporation  
7011 Industrial Dr.  
Mebane, NC 27302

Support Toll Free: 888-708-6610  
Telephone: (919) 563-6610  
E-mail: tech-support@majorpower.com

**Table Index**

CONNECTION GUIDE / TABLE 1 ..... 17  
 RESOLUTION GUIDE / TABLE 2 ..... 26  
 INVERTER ALARM CLASSIFICATIONS & RELAY MAP / TABLE 3 ..... 27  
 DC VOLTAGE THRESHOLDS / TABLE 4 ..... 27  
 OUTPUT CAPACITY RATING / TABLE 5 ..... 28  
 SINGLE PHASE AC VOLTAGE BYPASS / TABLE 6 ..... 28  
 SPECIFICATION 48 V / TABLE 7 ..... 31  
 SPECIFICATION 130 V / TABLE 8 ..... 32  
 STATEMENT OF TECHNICAL STANDARDS / TABLE 9 ..... 33  
 PART NUMBERS / TABLE 10 ..... 38