



Innovative Circuit Technology Ltd.



1500W Sine Wave Series Inverter

INSTRUCTION MANUAL
855-151-000

Models:

ICT1500-12SWTC

ICT1500-24SWTC

ICT1500-48SWTC

WARNING

Risk of serious personal injury or damage to equipment and property! Always observe the following:

- Use an appropriately rated over-current protection device in line with the main battery connection to the inverter.
- Use an appropriately rated over-current protection device in line with the AC input connection to the inverter.
- Use an appropriately rated disconnect switch or circuit breaker in line with the inverter DC and AC inputs to enable installation and service with the battery and ac power source disconnected.
- Connecting the inverter to the output of a DC distribution panel is not recommended as the inverter input's inrush may exceed the rating of the device, potentially causing damage to internal circuitry.
- Shut off or disconnect the DC and AC power sources before connecting or disconnecting wiring.
- Use wire and connectors rated for the maximum load current and size of fuse or circuit breaker, and keep cable lengths as short as practical.
- Ensure battery voltage matches the rating of the model of inverter in use.
- Carefully observe wiring polarity when making input connections.
- Securely tighten all connections.
- Use appropriate wiring strain relief devices on all wires when using the optional wiring box and cover.
- Ensure the rear AC input is connected to an external AC source (grid or generator) as the neutral line is NOT internally bonded to the chassis.
- Ensure chassis is connected to earth ground before use.
- Batteries can explode or arc! Wear suitable face and hand protection and use insulated tools when working with batteries.
- Do not attempt to service any internal parts. Refer all product service to an authorized ICT Ltd. service facility.

CAUTION

Risk of personal injury or damage to equipment! Always observe the following:

- Install in a protected environment, keep sources of moisture away from unit.
- Ensure the total power consumption of the load does not exceed the rated load capacity of the inverter.
- Do not block air inlet or outlet openings in the inverter
- Do not connect inverter output to an external AC transfer switch that may momentarily connect the output to an external AC source.

Rev 2.9 2025

Copyright © 2025 Innovative Circuit Technology Ltd. All rights reserved. No part of this publication may be reproduced, stored in a retrieval system or transmitted in any form or by any means, electronic, mechanical, photocopying, recording or otherwise, without the prior written consent of Innovative Circuit Technology Ltd.

Contents

INTRODUCTION	4
INSTALLATION	4
OPERATION.....	8
Status Indicators and Alarms.....	9
AC Transfer Switch	10
TCP/IP WEB-BASED UTILITY OPTION.....	11
Status and Control.....	12
Device Setup.....	13
Network setup.....	14
E-mail Setup.....	17
User Setup	18
Maintenance	19
MOBILE WEB APP	20
PASSWORD and IP ADDRESS RESET	21
ROUTER CONFIGURATION.....	22
TEXT MESSAGE ALARM NOTIFICATIONS	24
TROUBLESHOOTING	24
PRODUCT SPECIFICATIONS.....	25
LIMITED WARRANTY.....	28

INTRODUCTION

The ICT Sine Wave Series is a compact, high efficiency, true sine wave output, 1500-watt DC to AC inverter with features optimized for commercial applications.

- Continuous power rating of 1500 watts, with 3000-watt surge capability
- 115Vac 60Hz output with 93% peak efficiency
- Includes TCP/IP Ethernet port with built in web-server, and support for SNMP v1/v2 management systems for remote control and monitoring
- Includes automatic transfer switch with user-definable trip levels
- Includes convenient front AC outlets and/or hardwired rear AC terminal block
- Form C alarm contacts for remote notification of alarms
- Low EMI, FCC Class A compliance
- Temperature controlled variable speed fan for low noise and long life
- Optional 19" dual inverter rack mounting for installing 2 units side by side in a 2U rack space
- Optional DC wiring box for code compliant standalone installations

Model Numbers:

Models	Battery Voltage
ICT1500-12SWTC	12
ICT1500-24SWTC	24
ICT1500-48SWTC	48

Optional Accessories:

19" Rack Mount Tray (mount up to 2 inverters): ICT-RM2U
Wiring Junction Box (attaches to back of inverter): ICT-DCWB

INSTALLATION

Installation must only be done by technical personnel familiar with local electrical authority wiring requirements.

Perform a quick physical check of the unit as it is being taken out of the box to ensure it has not been damaged during shipping. Check for the included parts and accessories shipped with your unit:

- 3 pin Form-C alarm connector plug
- Wall mounting bracket, with mounting screws (4), installed
- Instruction Manual
- Bus bar (with 5/16-inch holes) hardware: 1/4-inch bolt, nut, and washer set (2)

Mount the optional wiring junction box base (part of the Wiring Junction Box kit ICT-DCWB) to the back of the inverter with four supplied screws, as shown in Figure 1. Knockout the plugs and install conduit fittings or wire strain relief clamps in the wiring box openings being used for the installation, as required. **When not using the back panel wiring junction box the inverter must be installed in a restricted access environment such as an enclosed equipment rack, in a location where unintentional bridging of the DC input connectors is unlikely.**

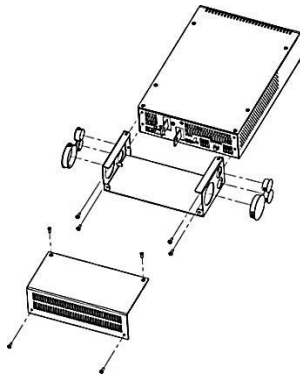

Figure 1: Wiring Junction Box Installation

Mount the inverter using the wall mount bracket (included) or the optional 19-inch Rack Mount Tray (ICT-RM2U) using the four mounting screws on the bottom of the inverter as illustrated in Figure 2. Keep the distance to the battery bank as short as practical to minimize power loss in the high current wiring.

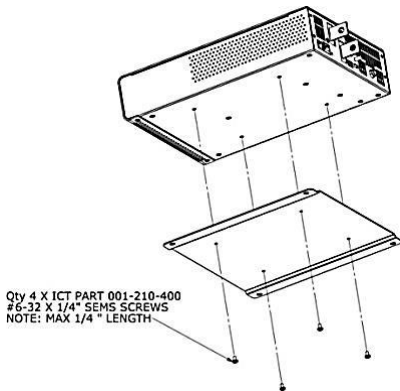

Figure 2: Inverter Wall Bracket Mounting

The inverter may be mounted horizontally on a shelf or the ICT rack tray, or in a vertical wall mounted orientation with either side located on top (as shown in Figure 3). Ensure front, sides, and rear air vents are not obstructed, to allow for

proper cooling and long term safe operation of the inverter (Mounting hardware not included).

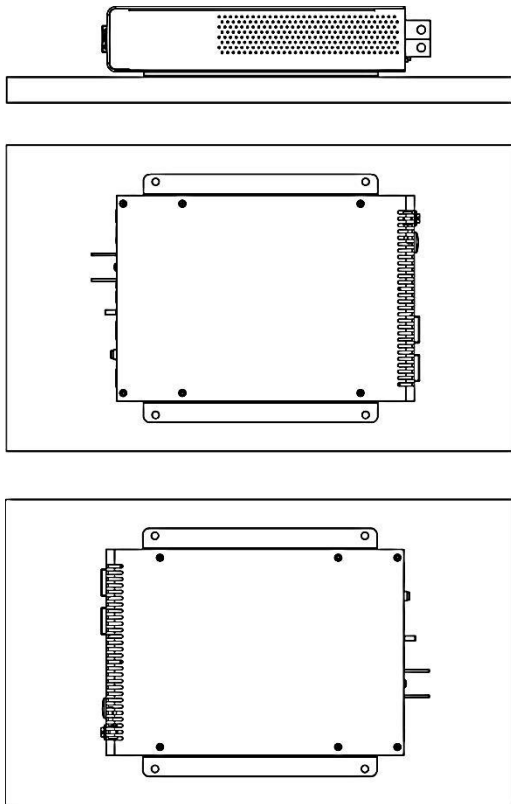

Figure 3: Approved Mounting Orientations

Connect the chassis Protective Earth (PE) ground stud on the back panel to a reliable earth ground point using suitable wire with ring tongue termination.

⚠ CAUTION

Risk of personal injury or damage to equipment!

The Protective Earth (PE) terminal must be connected to ground due to possible high touch current.

Ensure the nominal battery voltage is correct for the model of inverter, and that the battery polarity is correct. Reverse dc polarity will permanently damage the inverter.

Table 1: DC Input Sizing Guide, Recommended Minimum Battery Size

Model:	12V input	24V input	48V input
Min Battery Size	200Ahr	100Ahr	50Ahr
Max Bat Current	150A	75A	35A
Use Fuse/Breaker	175A	80A	40A

Ensure the inverter switch is in the off position, then connect the DC input wiring from a suitable deep-cycle lead-acid battery to the inverter back panel input bus bars using appropriately rated high current wire (as required by your local authority having jurisdiction) with an inline branch rated over current protection fuse or circuit breaker in the non-grounded battery lead (maximum rating as shown in Table 1). Terminate the wires with the appropriate size of crimp-on ring tongues to fit the 5/16" (7.9mm) input bus bar mounting holes. Connect the battery wiring with the input fuse removed, or with the battery circuit breaker switched to the "Off" position.

POS Input from Battery NEG Input from Battery Protective Earthing (PE) stud

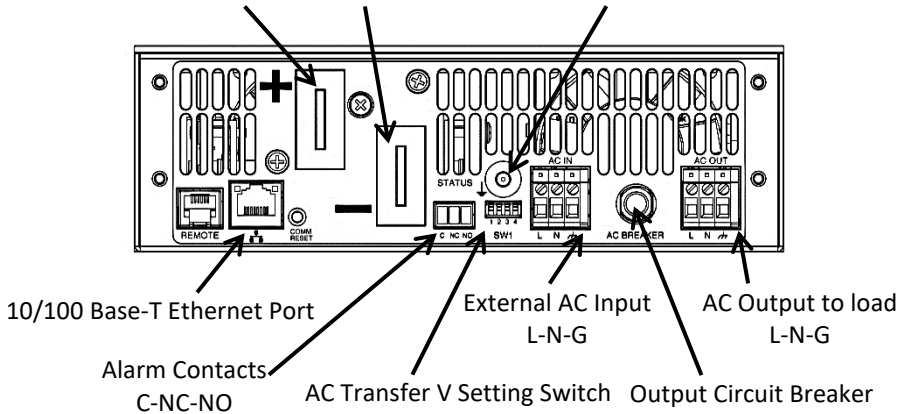

Figure 4: Back Panel Connections

Connect the AC loads to be powered by the inverter to the AC OUT wire clamp connector (Line, Neutral and Ground) located on the back panel (see Figure 4) using suitably rated wire. Alternatively, cord connected devices may be directly plugged in to the AC outlets located on the inverter front panel.

Connect an external AC power source (grid power or AC generator) to the AC IN wire clamp connector on the back panel of the inverter using suitably rated wire. This must be done before turning on the inverter as the neutral line is NOT internally bonded to the chassis. Ensure the external AC power source is switched off before making any connections. Branch rated overcurrent protection (fuse or

circuit breaker) must be provided in the external AC wiring source with rating as shown in Table 2.

Table 2: AC Input Over-Current Protection

Inverter Type:	External AC input Over Current Protection
115Vac 60Hz	115V 15A Max

 **CAUTION**

Risk of personal injury or damage to equipment!

AC input wiring from the grid or other power source to the inverter must be protected using a branch rated circuit breaker as shown in Table 2.

Do not use any external AC transfer switch that may momentarily connect the inverter output to an external AC source. This will damage the inverter!

Connect the external alarm monitoring wiring to the Form-C alarm contact output if desired (See Alarm Output Contacts table below). Plug the Ethernet network (CAT-5) cable in to the Network port on the back panel, routing the alarm and network cable through the plastic bushing immediately adjacent to the connector on the side of the optional wiring box tray.

Table 3: Alarm Output Contacts

Alarm Pin	Name	Description
1	C	Alarm output common
2	NC	Alarm output Normally Closed contact
3	NO	Alarm output Normally Open contact

Check that all connections to the inverter are correct and tight, then tighten the wire strain relief clamps in the wiring junction box (if used), and install the wiring box cover. **When not using the inverter wiring junction box all power wiring must be fixed to the rack or shelf to prevent any wire movement relative to the inverter connectors.**

OPERATION

With the unit mounted, wired, and powered as described in the INSTALLATION section, install the external battery fuse or set the battery circuit breaker to “on”, and move the front panel power switch to the “on” position. Check that the green AC indicator on the front panel is flashing slowly, indicating the inverter battery powered AC output is on.

Switch the external AC source disconnect device to ON and observe that the green AC indicator on the front panel is now on continuously, indicating the external AC

source is present and powering the load. The inverter output will now be powered directly from the external AC source.

The connected AC loads should now be operating normally, powered with up to 1500W (3000W momentary peak) of battery backed AC power.

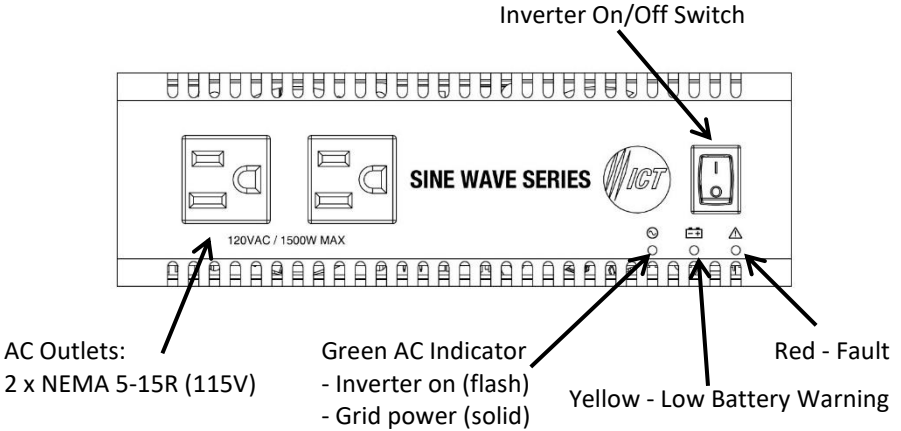

Figure 5: Front Panel

Status Indicators and Alarms

The 3 LEDs on the front panel and the Form-C alarm contacts on the back indicate the status of the inverter.

Alarm or Notification	Trigger Condition	Inverter Output	Red FAULT LED	Yellow WARN LED	Green AC LED
Inverter AC Output OK (Battery Backup Mode)	Normal operation, output above 90VAC	Enabled	-	-	BLINK
External AC Voltage OK	AC input is above set limit, and is powering the output	Enabled	-	-	ON
DC Undervoltage Warning	Triggers when input voltage drops below 11.0/22.0/44.0VDC for 1 s . Clears when input is above 11.2/ 22.4/ 44.8V for 1s .	Enabled	-	ON	-
Remote Shutdown	Triggers when remote shutdown is activated	OFF	BLINK	-	OFF

	over Ethernet, or remote panel switch				
System Fault	Indicates internal circuit fault - clears when all fault conditions are cleared.	OFF	ON	-	OFF
DC Undervoltage Shutdown	Triggers when input voltage drops below 10.5/21.0/42.0VDC for 1 s . Clears when input voltage rises above warning level for 1 s.	OFF	ON	-	OFF
DC Overvoltage Shutdown	Triggers when input voltage rises above 16.5/33/66VDC for 1 s . Clears when input voltage drops below 16.0/32/64VDC for 1 s .	OFF	ON	-	OFF
Over-temperature Shutdown	Triggers when internal temperature is too high. Clears when back to normal range.	OFF	ON	-	OFF
AC Output Failure	Triggers when inverter output problem detected. Must be cleared manually by toggling the power switch.	OFF	ON	-	OFF

The form-C alarm contact will be triggered for any condition that lights the red FAULT LED, or shuts down the output of the inverter.

AC Transfer Switch

The automatic AC transfer switch ensures that your load is primarily powered from the AC grid or generator when available, and is quickly transferred to the battery powered inverter output should the AC power source fail. Transfer time is typically less than one AC cycle, and the voltage transfer thresholds may be adjusted using the back panel DIP switch settings shown in Table 4. The output will be supplied by the inverter when the external line voltage is less than the Vac-Low setting, and will be transferred back to the external AC source when the voltage rises above the Vac-High setting.

Table 4: AC Transfer Switch Threshold Setting (**factory default in bold**)

Vac-Low Transfer	Vac-High Transfer	Switch settings (1 = "on", or down)			
		SW-1	SW-2	SW-3	SW-4
88 (190)	100 (206)	0	0	0	0
92 (197)	105 (215)	1	0	0	0
96 (205)	110 (224)	0	1	0	0
100 (214)	115 (233)	1	1	0	0
86 (188)	104 (212)	0	0	1	1
91 (197)	109 (222)	1	0	1	1
94 (204)	114 (230)	0	1	1	1
99 (212)	120 (240)	1	1	1	1

The 15A circuit breaker located on the back panel is a supplementary overcurrent protection device to limit the potential fault currents when operating from an external AC source. If this breaker trips it is indicating that the connected load is drawing excessive current from the unit, or that there is a fault with the AC wiring.

⚠ NOTE:

Disabling the inverter output will not cut power to the load if AC is being supplied by an external source via the internal transfer relay.

TCP/IP WEB-BASED UTILITY

Connecting the inverter to the internet using the TCP/IP communication port enables full remote monitoring and control of the inverter via the on-board graphical web interface using any standard web browser, such as Microsoft Explorer, Google Chrome, or Mozilla Firefox.

To connect with your networked inverter, do the following:

- Start your browser
- Enter the IP address of the inverter in the address field of your browser as shown:

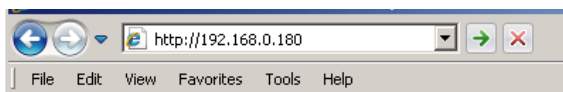

If the inverter is connected to a network with a DHCP server it will be assigned an IP address automatically. To find the current IP address of the inverter you will need to run the IP Address Discovery Utility (available on the Tools download section of the ICT Web page <http://www.ict-power.com/tools-utilities/>) to locate the connected inverter and see the assigned IP address. Run the utility on a

Windows computer connected to the same network as the inverter, and it will report the IP addresses of all ICT units connected to that network.

The inverter will otherwise use the factory default IP address of **192.168.0.180**, as shown above.

- Enter your username and password once you are connected to the unit. The default Administrator user name is **admin**, with no password.

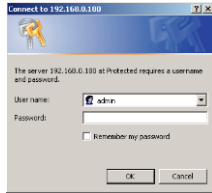

Figure 6: Typical Inverter Login Screen

Your browser will then be logged in to the inverter and the Status and Control page for the unit will be displayed as shown below. See the following section for descriptions on how to use the various monitoring and control features available through the inverter’s graphical web interface.

Status and Control

This page provides information on the input battery voltage, the inverter output voltage and power, whether the AC output is provided by the inverter or an external AC source and alarm status for the inverter. The inverter output may be enabled or disabled by clicking the on screen **On** or **Off** push button.

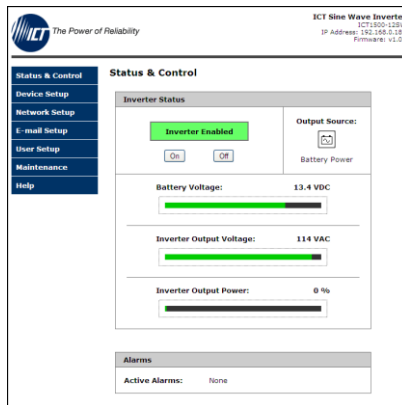

Figure 7: Status and Control Page

NOTE:

Disabling the inverter output will not cut power to the load if AC is being supplied by an external source via the internal transfer relay.

Device Setup

Use this page to configure the inverter settings. Click on the **Save Settings** button when finished to save and implement all new changes.

The screenshot shows the 'Device Setup' page for an ICT Sine Wave Inverter. The page has a blue navigation menu on the left with the following items: Status & Control, Device Setup, Network Setup, e-mail Setup, User Setup, Maintenance, and Help. The main content area is titled 'Device Setup' and contains two sections: 'Device Info' and 'Network Watchdog'. The 'Device Info' section has three fields: 'Device Name' (ICT Sine Wave Inverter), 'Model' (ICT1800-485W), and 'Hardware' (Version 01). The 'Network Watchdog' section has a checkbox for 'Watchdog Enabled', two input fields for 'Primary IP Address' and 'Secondary IP Address', a 'Watchdog Timeout' field set to 10 minutes(s) (1 - 60), and a 'Reset Delay' field set to 15 seconds (10 - 240). A 'Save Settings' button is located at the bottom of the form.

Figure 8: Device Setup Page

Device Info:

Device Name: Enter a custom descriptive name for the inverter, if desired.

Model: Displays the ICT model number for the inverter.

Hardware: Displays the hardware version of the inverter.

Network Watchdog:

Watchdog Enabled: Check this box to enable the watchdog feature, which will cause the unit to periodically ping up to two remote IP addresses to verify the network connection status. If there is no response from either address the unit will cycle the inverter output power. This feature is useful for rebooting a modem or other network device that is powered by the inverter, to help recover the network IP connection when one of these devices has crashed. The inverter output will be held in the off state for the duration set by the Reset Delay time, and then will be turned back on.

NOTE:

Disabling the inverter output will not cut power to the load if AC is being supplied by an external source via the internal transfer relay.

Primary IP Address: Enter the remote IP address you would like the inverter to monitor. If left blank the unit will monitor the Gateway IP address listed in the Network Setup page.

Secondary IP Address: Enter an optional second IP address that the unit can monitor to verify network status. The network watchdog will only trigger if both the primary and secondary IP addresses fail to respond.

Watchdog Timeout: Enter the time (1 to 80 minutes) that the remote IP address must stop responding to ping requests from the inverter, before the network watchdog will trigger an inverter output power cycle. Ensure this time is greater than the normal start-up time for the network hardware to prevent nuisance power cycle events at system start up.

Reset Delay: Enter the time (10 to 240 seconds) that the inverter will wait before re-enabling its output after a watchdog timeout. This delay must be long enough for any external networking equipment powered by the inverter to fully shut off, to force the equipment to re-boot when AC power is restored.

Network Setup

Use this page to configure the network settings. Click on the **Save Settings** button when finished to save and implement all new changes.

The screenshot shows the 'Network Setup' page of the ICT Sine Wave Inverter web interface. The page has a navigation menu on the left with options: Status & Control, Device Setup, Network Setup, E-mail Setup, User Setup, Maintenance, and Help. The main content area is titled 'Network Setup' and contains three sections: 'Network', 'Web Server', and 'SNMP'.
- The 'Network' section includes fields for MAC Address (00:04:A3:F4:75:68), a checked 'Enable DHCP' box, IP Address (192.168.0.180), Subnet Mask (255.255.255.0), Gateway (192.168.0.1), Primary DNS (192.168.0.1), and Secondary DNS (0.0.0.0).
- The 'Web Server' section includes fields for HTTP Port (80), HTTPS Port (443), and UDP Port (9383). A warning note states: 'Warning: Changing these ports may affect your ability to access the Inverter.'
- The 'SNMP' section includes checkboxes for 'Enable SNMP' and 'Enable SNMP Write Access', and text input fields for Read Community (public), Trap Community (public), Trap IP Addresses, Write Community (write), and SNMP Contact Information.
At the bottom of the page, there is a 'Save Settings' button and a note: 'Changing the Network Settings will reset the Communications on the Inverter.'

Figure 9: Network Setup Page

 **NOTE:**

Saving any changes to the network settings will cause the inverter to reboot, cycling power to the output.

Network:

MAC Address: Displays the MAC address assigned to the inverter.

Enable DHCP: Check this box (default) to turn on this setting if your network uses a DHCP server to automatically assign IP addresses. To manually assign a static IP address to the unit, uncheck this box and then set the following parameters.

IP Address: Enter a unique IP address for the unit.

Subnet Mask: Enter the mask for the subnet the inverter is located on.

Gateway: Enter the IP address of the default router (Gateway) used for connecting attached devices to different networks.

Primary DNS: Enter the IP address of the Primary DNS Server for your network.

Secondary DNS: Enter the IP address of the Secondary DNS Server for your network.

Web Server:

CAUTION:

Changing the web server port numbers may cause loss of communication with the inverter.

The following ports may be changed within a range of 1 to 65565, if required.

HTTP Port: Enter an HTTP port within the range of 1 to 65565. This port is used for HTTP traffic between the inverter and your browser. The default HTTP port is **80**, and if you change this, the new HTTP port number must be appended to the URL used to access the inverter (e.g. use URL **http://192.168.0.180:8000** for IP address **192.168.0.180**, port **8000**).

HTTPS Port: Enter an HTTPS (HTTP Secure) port within the range of 1 to 65565. This port is used for HTTPS traffic between the panel and the browser. This protocol uses encrypted data transfer between the panel and browser for higher security. The default HTTPS port is **443**. If a new HTTPS port is selected then the new HTTPS port number must be appended to the URL used to access the panel (e.g. use URL **https://192.168.0.180:8888** for IP address **192.168.0.180**, port **8888**).

UDP Port: Enter a UDP port within the range of 1 to 65565 to be used for applying firmware upgrades to the inverter. The default UDP port is **9393**.

SNMP:

Configure these settings if you would like to use SNMP based monitoring. SNMP (Simple Network Management Protocol) is an industry standard protocol for network management software. Enabling the SNMP function on the inverter will allow standard SNMP management software to connect to the SNMP agent running on the inverter and read real time system information such as battery voltage, and output power. The inverter can send SNMP traps to the external management software when an alarm or fault occurs.

The information available from the SNMP agent is described in a MIB (Management Information Base) file, which can be downloaded from the inverter's **Help** page. The unique inverter MIB file must then be imported into your external SNMP management software.

Enable SNMP: Check this box to enable the SNMP agent.

Read Community: Enter the community string/password for read-only SNMP access. The default read community string is "public".

Trap Community: Enter the community string/password that will be sent with all traps. Some trap receivers are able to filter based on Trap Community. The default trap community string is "public".

Trap IP Addresses: Enter the IP address for up to two devices that will receive SNMP traps from the inverter.

Enable SNMP Write Access: Check this box to allow remote SNMP control of the inverter output. If this box is unchecked information from the unit will be read-only.

Write Community: Enter the community string/password for read-write SNMP access. The default write community is "write".

 **NOTE:**

The community strings should be changed to unique passwords before enabling SNMP as the defaults are well known.

SNMP Contact Information: Enter contact information such as an operator name and phone number for the inverter, which can be read via SNMP queries. This information is optional.

E-mail Setup

Use this page to configure the email settings. The information required for this is available from your Network Administrator, or Internet Service Provider (ISP). Click on the **Save Settings** button when finished to save and implement all new changes.

ICT Sine Wave Inverter
ICT1500-1200
IP Address: 192.168.1.100
Firmware: v1.00

E-mail Setup

E-mail

SMTP Server:

SMTP Port:

SMTP Server requires SSL:

Sender E-mail Address:

Recipient E-mail Addresses:

SMTP User Name:

SMTP Password:

Minimum E-mail Interval: minute(s)

Use commas to separate multiple Recipient E-mail Addresses.
Leave the SMTP User Name & Password blank if the SMTP Server does not require authentication.

E-mail Notifications

Send an E-mail Notification when:

An Inverter failure occurs:

Inverter Communications reset:

The Network Watching triggers:

The Output switches between Inverter and Grid Power:

[Save Settings](#)

Figure 10: E-mail Setup Page

E-mail:

SMTP Server: Enter the name or the IP address of your SMTP server used for sending outgoing e-mail (e.g. "smtp.gmail.com").

SMTP Port: Enter the port used by your SMTP server (Normally 25).

SMTP Server requires SSL: Check this box if your SMTP server requires an encrypted SSL connection.

Sender E-mail Address: Enter an e-mail address that will appear as the sender for all e-mail notifications sent from the inverter.

Recipient E-mail Addresses: Enter one or more e-mail addresses that are to receive all e-mail notifications from the inverter. Use commas to separate multiple addresses. This field can also be used to send a text message notification to a phone; see the **Text Message Alarm Notifications** section for further information.

SMTP User Name: Enter an SMTP user name here, if required by your SMTP server. Leave this field blank if the server does not require authentication.

SMTP Password: Enter an SMTP password here, if required by your SMTP server. Leave this field blank if the server does not require authentication.

Minimum E-mail Interval: Enter a minimum interval required between e-mail notifications. Default is 0 and the range is 0 to 60 minutes. This time interval is used to prevent an un-intended flood of e-mail alarm notifications that could occur when an alarm limit is incorrectly configured, for example.

E-mail Notifications:

Select these options to receive an e-mail when one or more of these events occurs.

An inverter failure occurs: Check this box to receive an e-mail notification when the inverter has an internal fault.

Inverter Communications reset: Check this box to receive an e-mail notification when the inverter communications processor resets, normally due to either unit start-up or remote reset.

The Network Watchdog triggers: Check this box to receive an e-mail notification after the network watchdog triggers due to a loss of the network connection and the network has then come back online.

The Output switches between Inverter and Grid power: Check this box to receive an e-mail notification if there is a transition in the internal AC transfer relay due to the loss of the external AC source, or when it returns within the acceptable AC voltage range.

User Setup

Use this page to configure passwords for limiting access to the inverter settings. Click on the **Save Settings** button when finished to save and implement all new changes.

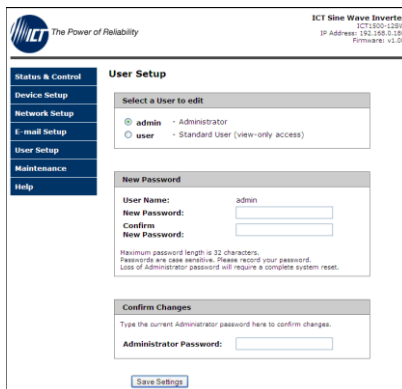

Figure 11: User Setup Page

The unit has no password assigned by default so an Administrator password should be assigned to your inverter for improved security.

 **NOTE:**

Record your new password for future access! If the administrator password is lost, the unit must be reset to return the password to the blank default setting which will also cause a reset to all the other settings. See the Password Reset section for more details.

Select a User to edit:

Select which of the two user accounts to edit.

Administrator (username: **admin**): This account has full access to the inverter settings.

Standard User (username: **user**): This account has read-only access to the inverter, and cannot enable or disable the outputs, or change any of the inverter settings.

New Password:

Use these fields to change the password of the selected user.

New Password: Enter the new password for the chosen user.

Confirm New Password: Re-enter the new password to confirm the entry.

Confirm Changes:

Administrator Password: Enter the current password prior to saving the settings to confirm the new password changes.

Maintenance

Use this page to reset the inverter communications port (soft reset), restore its factory default settings, or send a test e-mail to verify e-mail functionality.

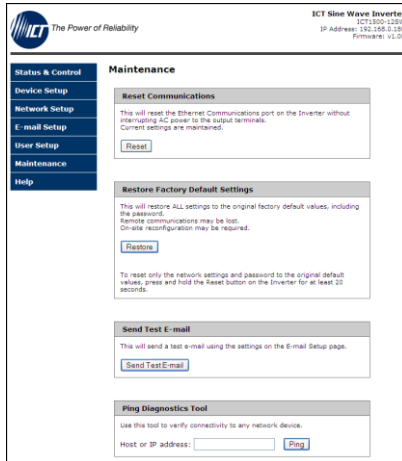

Figure 12: Maintenance Page

Reset Communications:

Click the **Reset** button to restart the communication processor which will reset the Ethernet communication port without interrupting the AC output. All other settings are maintained.

Restore Factory Default Settings:

Click the **Restore** button to restore ALL settings to the original factory default values including the user passwords. To only restore the network settings and passwords see the **Password Reset** section.

Send Test E-mail:

Click the **Send Test E-mail** button to send a test e-mail to the listed e-mail recipients using the e-mail settings on the **E-mail Setup** page.

Ping Diagnostics Tool:

Use this feature to verify connectivity of any network connected device. Enter the hostname or IP address of the target device, and then click the **Ping** button.

MOBILE WEB APP

Use the mobile version of the **Status and Control** page to monitor and control the inverter with a smartphone web browser.

Access the Mobile Web App by entering the address of the inverter in the address field of your browser, followed by **"/m"** (e.g. **https://192.168.0.180/m**). You will then be prompted for your username and password, and logged into the following **Status and Control** screen:

For improved security you should normally use a HTTPS (secure) connection when accessing the inverter over the Internet with the Mobile Web App, or use a Virtual Private Network (VPN) connection.

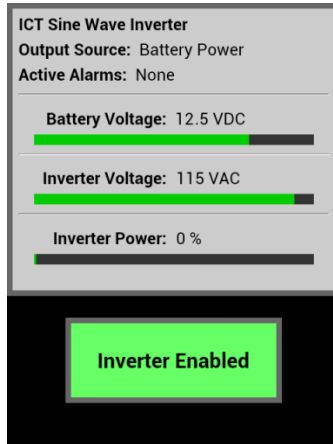

Mobile Web App

As shown above the Mobile Web App provides information on Battery Voltage, Inverter Output Voltage, Inverter Output Power, Output Power Source (from battery, or external AC source), and any alarms. Tap on the **Inverter Enabled** button to toggle the inverter output power on or off.

PASSWORD and IP ADDRESS RESET

Reset the administrator password, the IP address, and network settings to the original factory default values by doing the following (the standard user password is not affected).

1. With unit powered on, press and hold the recessed **COMM RESET** button on the back panel for approximately 20 seconds, using a paper clip wire or similar item to press the button.
2. Release the button.

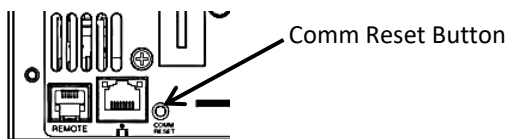

ROUTER CONFIGURATION

Use this section to set up an inverter with remote internet access when located behind a router.

A router allows multiple PC to share a single internet connection, and must be configured correctly to forward incoming remote data to the local IP address of your inverter.

Example configuration using a Linksys WRT54G router: (others will be similar)

1. Log into your router and go to the port forwarding screen. In the example Linksys WRT54G router, this is located in the Applications and Gaming tab. The location of the port forwarding fields may be different on your particular router (consult the router manual for instructions).
2. Configure HTTP forwarding:
 - a. Enter a unique name in the **Application** field.
 - b. Enter the HTTP port number that the inverter is using in the **Start** and **End** fields. The default HTTP port for the inverter is **80**.
 - c. Select **Both** under **Protocol** (TCP and UDP).
 - d. Enter the local IP address of the inverter (e.g. 192.168.0.180) in the **IP address** field (see step 2 of the **TCP/IP Web-Based Utility** section to verify the inverter IP address).
 - e. Check the **Enable** box, and then click on **Save Settings**.

NOTE:

Many ISP block access to port 80 so if your ISP does block this port you must change the HTTP port the inverter uses from 80 to something else such as 8000. Valid port numbers are in the range of 1 to 65535. See the Network Setup section for information on assigning new network ports.

You must also change the inverter's HTTP port from 80 if your local network has another device (such as a web server) already using port 80.

3. Configure HTTPS forwarding by repeating steps 2a to 2e with the HTTPS port number that the inverter is using. The default HTTPS port number is **443**.
4. Set up your router to allow remote firmware upgrades to the inverter by repeating steps 2a to 2e with the UDP port number the inverter is using (default UDP port is **9393**). This step is optional if firmware upgrades are to be done locally.

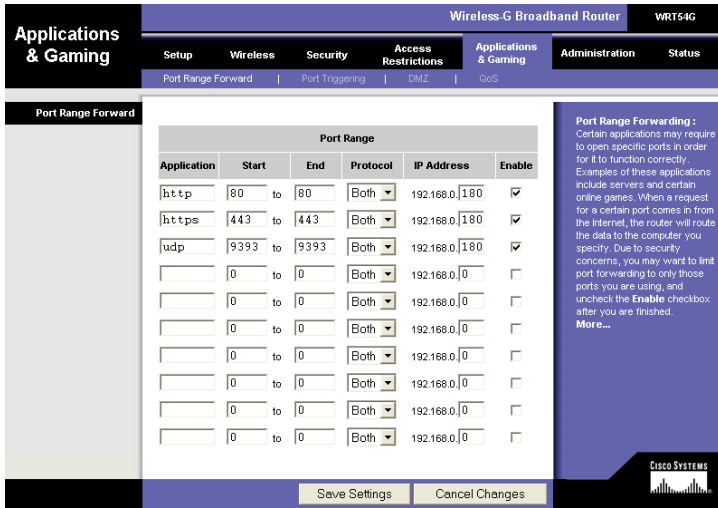

Figure 13: Typical Router Port Forwarding Screen

- Determine the WAN IP address of your router assigned by the ISP. With the example router this information is on the **Status** tab, listed as **IP Address**.

NOTE:

When using a dynamic IP address the router's WAN IP address may change from time to time without warning, depending on your ISP. In this case you should obtain a Static IP address from your ISP (it will not change) which will ensure more predictable access to the inverter from a remote location. If a static IP address is not available you can use a Dynamic DNS service such as Dyn (www.dyn.com) to provide a stable address for the router.

- To access the inverter over the internet type the WAN IP address of the router in the location/address field of your browser, followed by a colon and the HTTP port number the inverter is using (e.g. **http://209.123.10.33:8000** for a router address **209.123.10.33**, port **8000**).

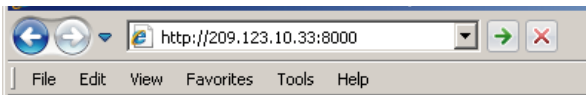

Figure 14: Inverter Access with Router Address

TEXT MESSAGE ALARM NOTIFICATIONS

The inverter can send alarm notifications as text messages to a cell phone by configuring the alarm e-mails to be sent to your mobile phone service provider. On the **E-mail Setup** page of the web-based utility, enter the text address of your phone in the **Recipient E-mail Addresses** field.

Example with an AT&T phone: enter the recipient address **cellnumber@txt.att.net**, replacing **cell number** with your 10-digit cell phone number.

Cell address formats for some common North American mobile phone providers:

AT&T	<i>cellnumber@txt.att.net</i>
Verizon	<i>cellnumber@vtext.com</i>
Sprint	<i>cellnumber@messaging.sprintpcs.com</i>
T-Mobile	<i>cellnumber@tmomail.net</i>
Virgin Mobile	<i>cellnumber@vmobl.com</i>
Nextel	<i>cellnumber@messaging.nextel.com</i>
Bell Mobility	<i>cellnumber@txt.bell.ca</i>
Rogers	<i>cellnumber@pcs.rogers.com</i>
Telus	<i>cellnumber@msg.telus.com</i>
Virgin Mobile (Can)	<i>cellnumber@vmobile.ca</i>

TROUBLESHOOTING

I am unable to access the web-based configuration utility.

- Check that you are using the correct IP address for the inverter by running the IP Address Discovery Utility (available on the Tools download section of the ICT Web page <http://www.ict-power.com/tools-utilities/>) to locate the connected inverter and see the assigned IP address. Run the utility on a Windows computer connected to the same network as the inverter, and it will report the IP addresses of all ICT units connected to that network. The IP address may have been changed if DHCP is enabled.
- Ensure you are using an industry standard “crossover” type of network cable if directly connecting a computer to the inverter, and a “straight-through” type of cable to connect the inverter to a network.
- Ensure the network card settings on your computer are configured for accessing the IP address of the inverter. To access a unit with the default IP address of 192.168.0.180 the typical network settings for your computer are:
 - IP Address: 192.168.0.180
 - Subnet Mask: 255.255.255.0
 - Gateway: 192.168.0.1

- If the HTTP port of the inverter has been changed, you must append the new port number to the URL used to access the unit (see the **Network Setup** section). See the **Password Reset** section for details on how to reset the port number to the factory default value.
- If your network switch allows you to manually configure port speed and duplex settings, turn-on “**Auto Negotiation**” for the switch port that the inverter is connected to.

I forgot my password.

- See the **Password Reset** section of the manual.

I am not receiving e-mails from the inverter.

- Verify that the **Send-E-mail** checkboxes are ticked for any alarm conditions for which you wish to receive e-mail notifications.
- Verify your e-mail settings by going to the **Maintenance** page on the inverter’s web-based utility and clicking on the **Send Test E-mail** button. This will send a test message to your designated recipient addresses. The **Send Test E-mail** page will show an error message if the unit is unable to send the e-mail.
- Check on the **E-mail Setup** page and ensure the **SMTP Server** field is the correct address for your e-mail provider, and the **SMTP Port** is correct. (Port should be 25 for most servers)
- If your SMTP server requires SSL encryption, ensure the **SMTP Server requires SSL** checkbox is ticked otherwise leave blank.
- If your SMTP server requires authentication ensure that the **SMTP User Name** and **SMTP Password** fields are correctly entered.

PRODUCT SPECIFICATIONS

Continuous Output Power:	1500W
Surge Power (2 seconds):	3000W
Peak Efficiency (typical):	93%

Input Voltage (Current):	
12V model	10.5 to 16.0Vdc (150A)
24V model	21.0 to 32.0Vdc (75A)
48V model	42.0 to 64.0Vdc (35A)
Battery Low Shutdown:	
12V model	10.5Vdc
24V model	21.0Vdc
48V model	42.0Vdc
No Load Power Draw:	< 22W
Switched Off Power Draw:	< 15mW
Output Frequency (115Vac models):	60Hz +/- 0.2Hz
Output Voltage (115Vac models):	115Vac +/- 5Vac
Output Sinewave Distortion (typical):	< 3% THD
Transfer Time (Grid to Inverter):	< 1 cycle
Ethernet Network Port:	RJ45 connector, 10/100Base-T
SNMP:	SNMP v1/v2c supported
Alarm Output:	Form-C contact, 0.5A 60Vdc max
DC Input Connectors:	Bus Bar, 5/16" (8mm) hole
AC Input/Output Connectors (rear):	3 terminal cage clamp 20A max, 12 – 16 AWG, 0.5N-m
Front AC Outlet (115Vac models):	2 NEMA 5-15R, 120V 15A
Alarm Connector:	Removable plug, cage clamp type 16 – 28AWG
Operating Temperature Range:	-20C to +40C
Humidity:	10 – 90% (non-condensing)

Cooling:

Temperature controlled fans
(2)

Dimensions (inches):

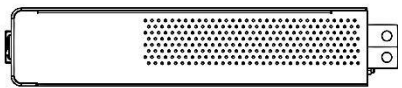
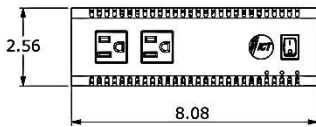
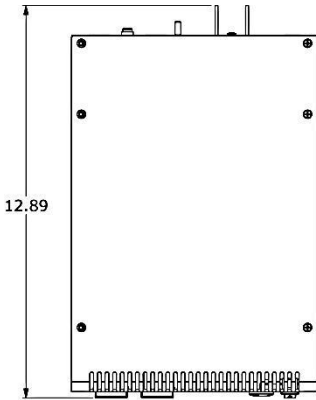

Weight: (lbs/kg)

8lbs / 3.6kg

NOTE: This equipment has been tested and found to comply with the limits for a Class A digital device, pursuant to part 15 of the FCC Rules. These limits are designed to provide reasonable protection against harmful interference when the equipment is operated in a commercial environment. This equipment generates, uses, and can radiate radio frequency energy and, if not installed and used in accordance with the instruction manual, may cause harmful interference to radio communications. Operation of this equipment in a residential area may cause harmful interference in which case the user will be required to correct the interference at their own expense.

ICT LIMITED WARRANTY

ICT Limited Warranty is only intended for the benefit of the original Purchaser of this product. This Warranty is not transferable or assignable without the prior written permission of ICT. ICT's sole obligation and liability under this warranty is limited to either repairing or replacing defective products at the sole discretion of ICT. When repairing or replacing the products, ICT may use products or parts that are new, equivalent to new or re-conditioned. Parts repaired or replaced during the warranty period will be under warranty for the remainder of the warranty period.

The warranty period on ICT products purchased new from ICT is two years. The warranty period for a repaired product or part thereof is ninety (90) days or the remainder of the unexpired term of the new product warranty period, whichever is greater. Repair or replacement of a defective product or part does not extend the original warranty coverage period.

No claim will be accepted unless written notice of the claim is received by ICT in accordance with ICT's Return Material Authorization (RMA) procedure, as soon as reasonably possible after the defect is discovered. A valid product serial number must be provided with the RMA claim to prove eligibility. The RMA form is available on the ICT website at www.ict-power.com/support/warranty-repair/.

The Purchaser shall at their own risk and cost return the defective product to ICT's factory or designated repair center once an RMA is issued by ICT. Return of the products to the customer after repair is completed shall be prepaid by ICT unless otherwise mutually agreed between the parties. Products shipped to ICT which have incurred freight damage will not be covered by this Warranty and any repairs or replacement parts, components or products needed will be invoiced in the full current price amount and returned freight collect to Purchaser. It is the Purchaser's responsibility to check the product upon receipt for any damage during shipping and to contact the carrier or shipper regarding such damage. Product that is returned as defective, which is determined to operate within published specifications will be returned to the Purchaser freight collect.

Warranty commences on the date the product is shipped from the ICT manufacturing facility, or in the case of purchase through an authorized ICT reseller, not more than ninety (90) days after original shipment of this product by ICT.

ICT assigns to Purchaser any warranties which are made by manufacturers and suppliers of components of, or accessories for, the ICT product and which are assignable. ICT makes no representations as to the effectiveness or extent of such warranties, assumes no responsibility for any matters which may be warranted by such manufacturers or suppliers and extends no additional coverage under this Warranty to such components or accessories.

In no event shall ICT be liable for any special, indirect or consequential damages such as, but not limited to, loss of use, business or goodwill, loss of revenue, or loss of profits, which may result, either directly or indirectly, from defects in products provided by ICT.

This Warranty will be void if the product has been subjected to misuse, neglect, accident, exposure to environmental conditions not conforming to the products' limits of operation, improper installation or maintenance, improper use of an electrical source, defects caused by sharp items or by impact pressure, a force majeure event, has been modified or repaired by anyone other than ICT or its authorized representative, has been subjected to unreasonable physical, thermal or electrical stress, improper maintenance, or causes external to the unit including but not limited to general environmental conditions such as rust, corrosive atmospheres, sustained temperatures outside the specified operating range of the equipment, exposure to power surges and/or electrical surges, improper grounding, mould or dust, animal or insect damage, water damage or immersion in liquid of any kind, or if the serial number has been altered, defaced, or removed.

ICT does not control the installation and use of any ICT product. Accordingly, it is understood this does not constitute a warranty of performance or a warranty of fitness for a particular purpose.

This Warranty represents the entire agreement between ICT and Purchaser with respect to the subject matter herein and supersedes all prior verbal or written communications, representations, understandings or agreements relating to this subject.

INNOVATIVE CIRCUIT TECHNOLOGY LTD.
26921 Gloucester Way
Langley, British Columbia, Canada V4W 3Y3
T 604.856.6303 F 604.856.6365 www.ict-power.com